

Section I

15 Marks

Attempt Questions 1 – 15

Allow about 25 minutes for this section

Use the multiple-choice answer sheet for Questions 1 –15.

- 1 Which of the following diagrams correctly shows the direction of electric field lines between two parallel charged plates?

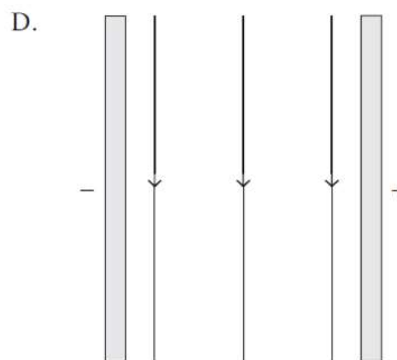
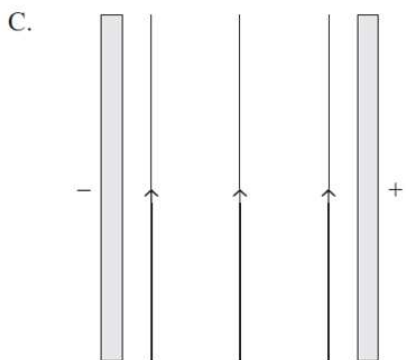
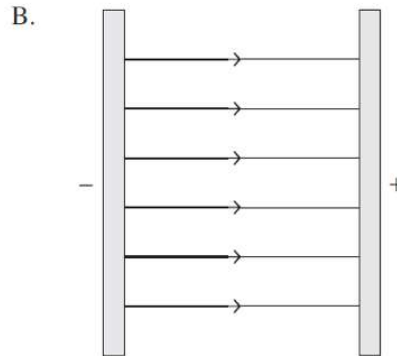
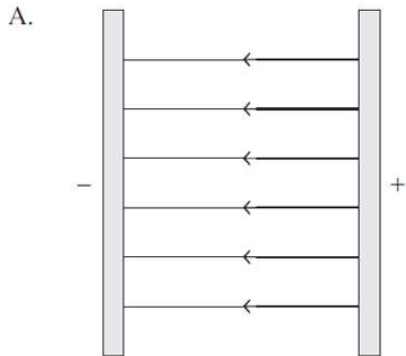

- 2 A person enters an elevator in a multi-story building and stands on a set of digital bathroom scales. The reading on the scales is 60 kg. A short while after the doors to the elevator close, the person notices that the reading on the scales is 70 kg.

This change most likely occurred because the elevator was:

- (A) travelling at a constant speed to a lower level.
- (B) travelling at a constant speed to a higher level.
- (C) accelerating to a lower level.
- (D) accelerating to a higher level.

- 3 A set of darts was used to represent the result of an investigation which was repeated four times and then an average taken.

Which is the best match for the results?

(A)

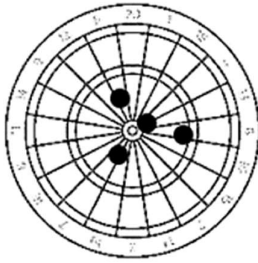

(B)

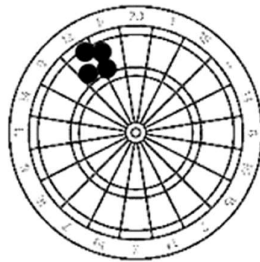

(C)

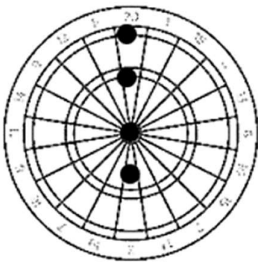

(D)

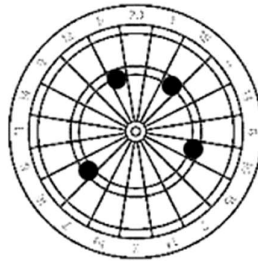

(A)

(B)

(C)

(D)

	<i>Reliability</i>	<i>Accuracy</i>
(A)	High	Low
(B)	High	Low
(C)	High	High
(D)	Low	High

- 4 Earth has a mass of 6.0×10^{24} kg. The Moon has a mass of 7.3×10^{22} kg.

Which of the following statements describes the interaction between Earth and the Moon?

- (A) The Earth pulls on the Moon with a force that is greater than the force that the Moon pulls on Earth.
- (B) The Moon pulls on Earth with a force that is greater than the force that Earth pulls on the Moon.
- (C) The Earth pulls on the Moon with a force of the same magnitude as the force that the Moon pulls on Earth.
- (D) The Earth experiences a greater acceleration than the Moon because the Moon has a smaller mass.

5 How much energy is dissipated by a heating coil that has a resistance of 5.0Ω when a current of 6.0 A flows through it for one minute?

- (A) 30 J
- (B) 180 J
- (C) 9.0 kJ
- (D) 10.8 kJ

6 A negatively charged rod is held close to a metal ball suspended on a string. What happens to the ball?

- (A) The ball is not affected by the rod as it is not touching the ball.
- (B) Positive charges in the ball move towards the right and the ball is attracted to the rod.
- (C) Negative charges in the ball move towards the right and the ball moves away from the rod.
- (D) Negative charges in the ball move towards the left and the ball moves towards the rod.

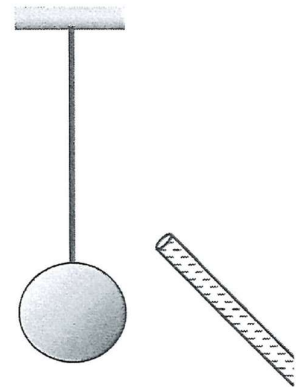

7 A long wire is carrying 10 A of current out of page.

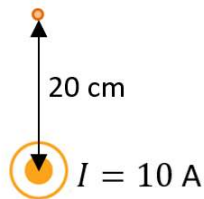

Which of the following correctly shows the direction of the magnetic field due to the current as seen from the front of the page and the magnitude of the magnetic field measured 20 cm above the wire?

	<i>Direction of magnetic field</i>	<i>Magnitude of magnetic field (T)</i>
(A)	Clockwise	1.0×10^{-5}
(B)	Clockwise	5.0×10^{-5}
(C)	Anti-clockwise	1.0×10^{-5}
(D)	Anti-clockwise	5.0×10^{-5}

- 8 Two blocks of wood are pushed along a frictionless horizontal surface with a force of 200N as shown below.



Block A has a mass of 50 kg and Block B has a mass of 30 kg.

What is the magnitude of the force exerted by Block B on Block A?

- (A) 75 N
(B) 125 N
(C) 200 N
(D) 294 N
- 9 Total internal reflection in optical fibres is widely used in communication. The flexible glass fibres can bend around corners but there are limits. If the bend is too tight, light (and hence data) can be lost.

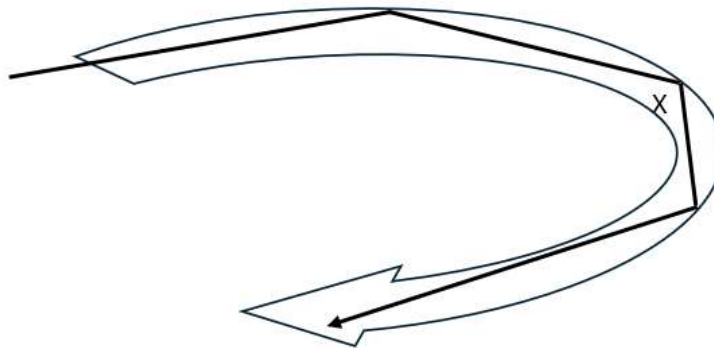

If an optical fibre has a refractive index of 1.48, at what angle (X) will light begin to escape?

- (A) $< 42.5^\circ$
(B) $> 42.5^\circ$
(C) $< 85^\circ$
(D) $> 85^\circ$

- 10 Two point charges, q_1 and q_2 are separated by a distance of 4.00 cm. q_1 has a charge of $+5.00 \mu\text{C}$ while q_2 has a charge of $+8.00 \mu\text{C}$. What is the magnitude of the force exerted on q_1 by q_2 ?

- (A) 8.99 N
- (B) 225 N
- (C) 2.25×10^8 N
- (D) 2.25×10^{10} N

- 11 A simple solenoid made by wrapping wire around a cardboard cylinder is attached to a voltage source.

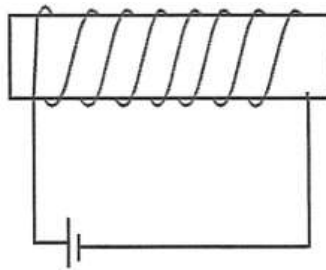

Which of the following changes would produce the greatest increase in magnetic field strength at the centre of the solenoid if the voltage supplied and the number of turns is kept constant?

- (A) increasing the diameter of the solenoid
 - (B) increasing the thickness of the wire making up the solenoid
 - (C) increasing the length of the solenoid
 - (D) using an alternating current instead of a direct current
- 12 A sound is measured to have an intensity of $7.6 \times 10^{-1} \text{ Wm}^{-2}$. The measurement was taken at a distance of 4.5 m from the source of the sound. What is the power rating of the source?
- (A) 3.4 W
 - (B) 15 W
 - (C) 48 W
 - (D) 193 W

- 13 A stationary observer sees an aeroplane flying directly towards them at a constant speed of 221 ms^{-1} . The observer hears a sound coming from the aeroplane that has a frequency of 1200 Hz as it flies towards them.
- What is the frequency of the sound heard by the observer as the aeroplane flies away from them?

- (A) 255 Hz
- (B) 420 Hz
- (C) 1980 Hz
- (D) 3430 Hz

- 14 A 3 kg mass moves at a velocity of 0.4 ms^{-1} on a frictionless surface and collides with a stationary mass (1.5 kg). The velocity and direction of the 3 kg mass before and after the collision, are shown in the diagram below (viewed from above).

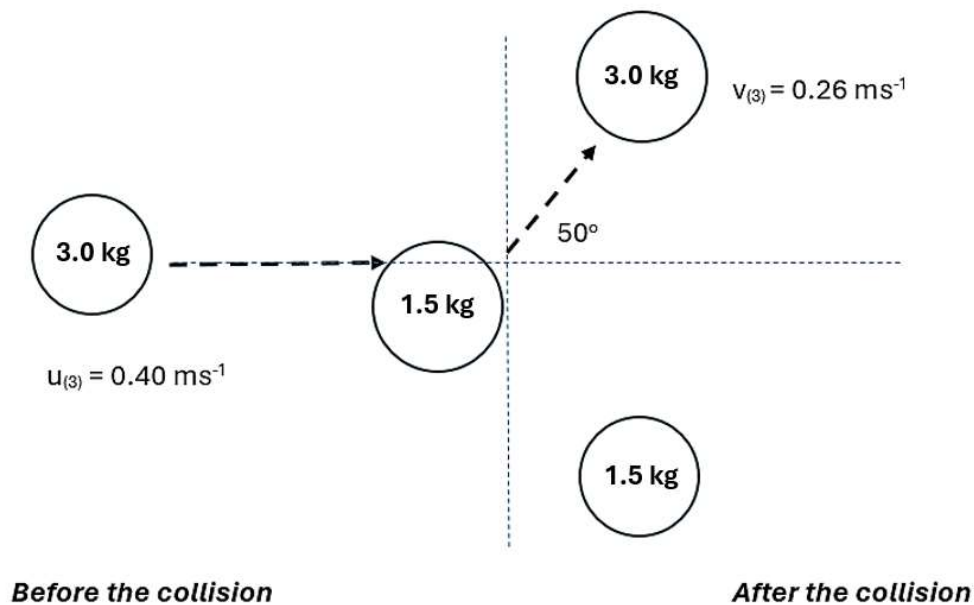

What is the momentum of the 1.5 kg mass after the collision?

- (A) 0.61 kgm^{-1}
- (B) 0.78 kgm^{-1}
- (C) 0.92 kgm^{-1}
- (D) 1.20 kgm^{-1}

- 15 During a daring acrobatic performance at a circus, one acrobat is standing on the shoulders of another acrobat. A third person, dressed as a clown, is projected 3 metres upwards onto the shoulders of the top person, when a fourth person jumps down from a box that is 1.5 metres in height, onto a device that propels the clown upwards.

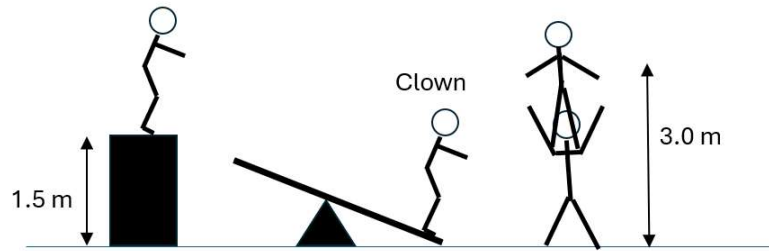

What is the approximate mass of the person who jumps from the box if the clown has a mass of 45 kg?

- (A) 45 kg
- (B) 60 kg
- (C) 80 kg
- (D) 100 kg

End of Section I

Question 16 (4 marks)

Two trucks (A and B) are travelling along separate roads at constant speed towards an intersection as shown in the diagram below. Both trucks are travelling at 25 ms^{-1} . One road is North-South, and the other is East-West. The North-South road passes over the top of the East-West road.

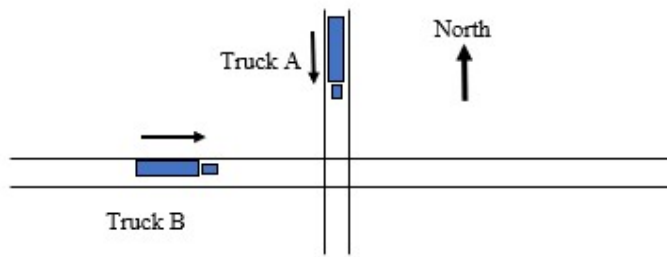

- (a) Draw a vector diagram that shows the velocity of truck B with respect to truck A. 2
State the magnitude and the direction of the velocity of truck B with respect to truck A on the diagram.

- (b) Calculate the displacement of truck A with respect to truck B, 20 seconds after they simultaneously pass over/under each other. 2

.....

.....

.....

.....

.....

.....

Question 17 (3 marks)

The diagram shows two square wave pulses travelling towards each other. Each pulse is moving at a speed of 1.5 ms^{-1} .

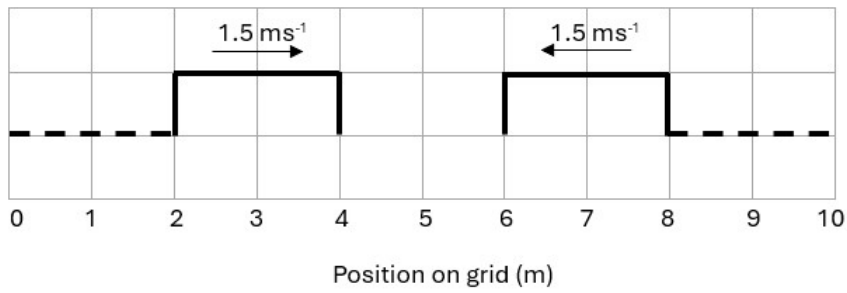

(a) Complete the diagram below to show what these pulses look like 1.0 s later.

2

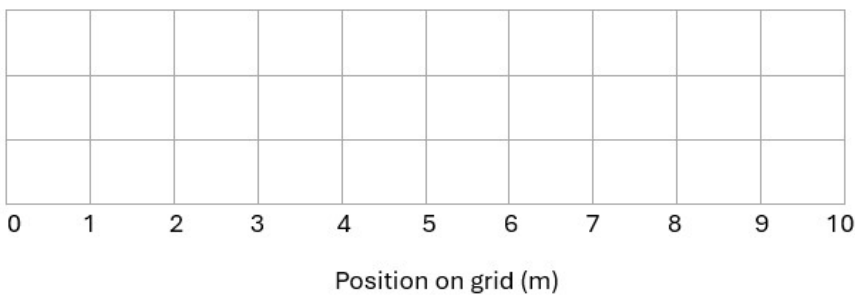

(b) Identify the name of the wave principle that determine the result when two waves overlap in a medium.

1

.....

Question 18 (6 marks)

The velocity vs time graph for an object travelling in a straight line on a horizontal surface is shown below.

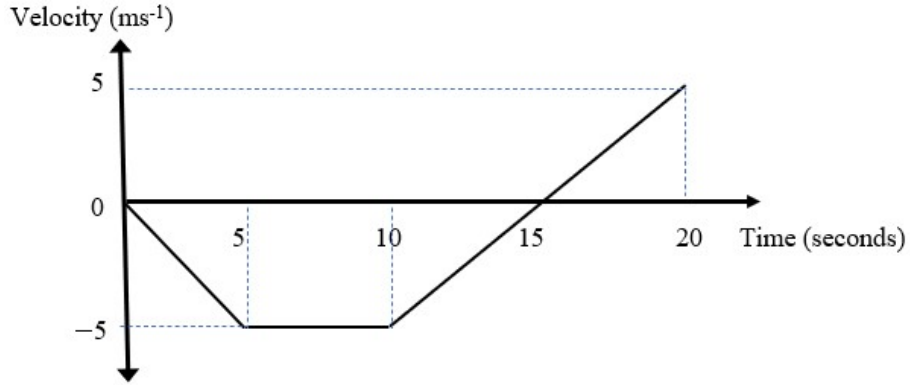

- (a) Quantitatively describe the motion of the object during the first 10 seconds. 2

.....

.....

.....

.....

- (b) Calculate the distance travelled by the object between 10 and 20 seconds. 2

.....

.....

.....

.....

- (c) In the space below, draw a displacement vs time graph for the motion of the object over the 20 second period. 2

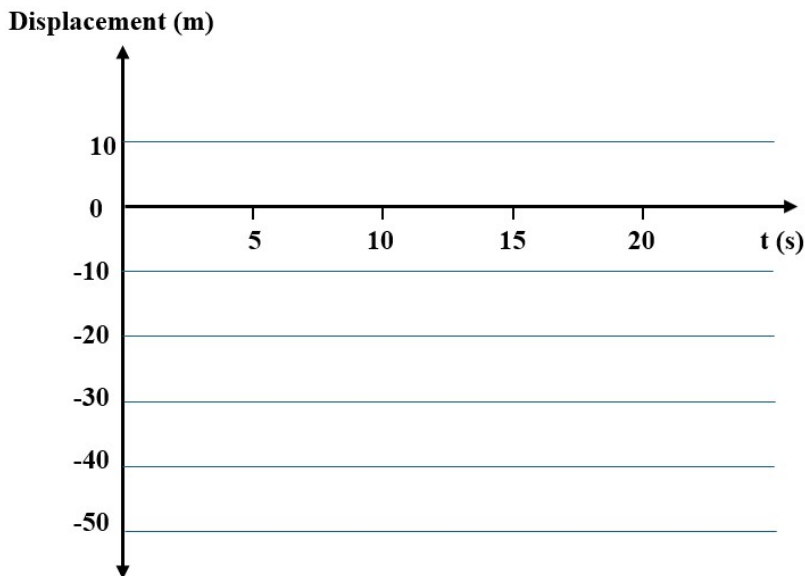

Question 19 (5 marks)

Two people go fishing. At the beginning of the day, they launch the boat (mass = 1200 kg) at a boat ramp by allowing the boat to slide freely off the boat trailer into the water. The boat ramp has an angle of 10° .

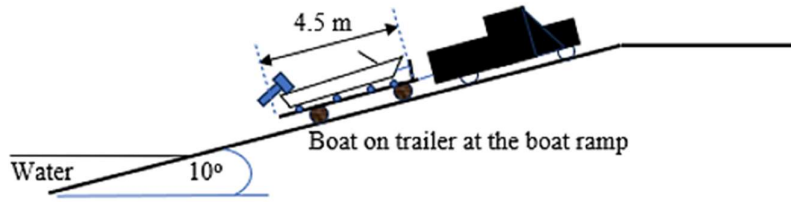

- (a) Assuming that the rollers on the trailer has no resistance to the movement of the boat, calculate the acceleration of the boat before it enters the water. **1**

.....

.....

.....

.....

- (b) After fishing, an electric winch is used to pull the boat back onto the trailer at the same boat ramp. If the winch moves the centre of gravity of the boat through a distance of 2.25 metres in 8 seconds when pulling the boat onto the boat trailer, determine the minimum power that the winch provides. **2**

.....

.....

.....

.....

- (c) Before the boat is towed away on a trailer, it is secured by a chain that prevents it from rolling backwards. Draw a labelled diagram to show how the forces that act on the boat are balanced, while it is on the trailer on the ramp and held by the chain. **2**

Question 20 (5 marks)

When investigating the effectiveness of crumple zones on the front of motor vehicles, collisions between test crash vehicles and concrete barriers provide valuable information about safety features of cars and trucks.

The graph below represents the force on the front of a test crash car ($m = 2000 \text{ kg}$) from the time it runs into a concrete crash barrier and when it stops.

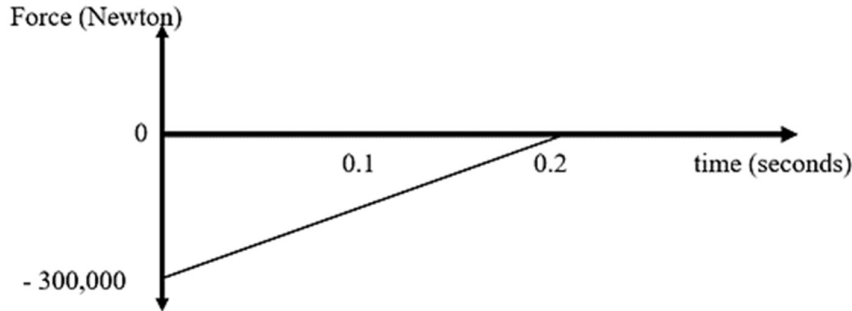

- (a) Calculate the maximum acceleration of the test crash car. 1

.....

.....

- (b) Calculate the speed that the test car was travelling, immediately before it hit the concrete wall. 2

.....

.....

.....

.....

.....

.....

- (c) Is the collision elastic or inelastic? Explain why. 2

.....

.....

.....

.....

.....

.....

Question 21 (4 marks)

An object is placed between the principal focus, f , and the centre of curvature, C , of the concave mirror, as shown in the diagram below.

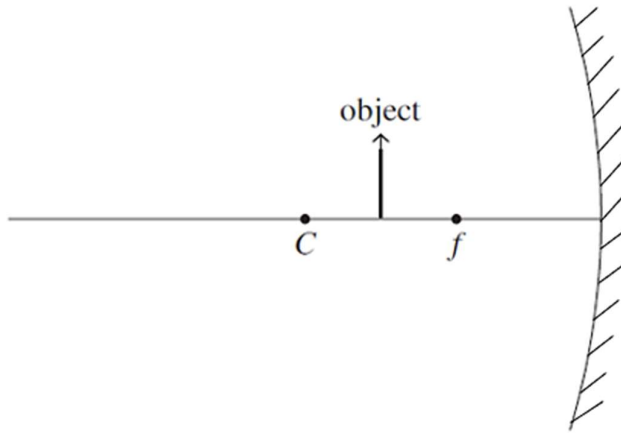

(a) On the diagram above, draw rays to show the location of the image produced. 2

(b) Identify the nature of the image 2

.....
.....

Question 22 (6 marks)

A person produces a list of the steps they used to make a cup of coffee.

1. Place 500 mL of clean tap water (at 20°C) into an empty electric kettle.
2. Turn on the kettle and wait for it to boil.
3. Pour 200 mL of boiling water (at 100°C) into a porcelain mug (at 20°C) containing a small amount of instant coffee.
4. Stir gently with a spoon for 10 seconds.

- (a) If it takes 1 minute and 35 seconds for the 500 mL of water to boil, calculate the minimum effective power of the electric kettle. 1

.....

.....

- (b) If the porcelain mug has a specific heat capacity of $1100 \text{ Jkg}^{-1}\text{C}^{-1}$ and a mass of 340 g, determine the maximum temperature of the coffee after the mug and the coffee (i.e. water) have reached thermal equilibrium (assume there are no heat losses to the surroundings while thermal equilibrium is being reached). 3

.....

.....

.....

.....

.....

.....

.....

.....

- (c) The student noticed that the temperature of the coffee decreased slightly when the coffee was stirred with a metal spoon. 2
Provide a thermodynamic explanation for why this temperature change occurred.

.....

.....

.....

.....

.....

Question 23 (6 marks)

A student conducts an experiment to measure the electrostatic force between two identical, charged objects at various distances. Data obtained from the experiment is shown in the table below.

<i>Data point</i>	<i>Distance (m)</i>	<i>1/distance² (m⁻²)</i>	<i>Electrostatic force (N)</i>
1	0.03	1110	40.0
2	0.04	625	22.5
3	0.05	400	14.5
4	0.06	278	10.0

- (a) Using *Data point 1*, calculate the magnitude of the charge on each object. 2

.....

.....

.....

.....

.....

- (b) Plot the data points on the axes provided. Include a trendline. 2



- (c) Use the gradient of the trendline in (b) to determine the value of the electric permeability constant, ϵ_0 . 2

.....

.....

.....

.....

.....

Question 24 (5 marks)

In an experiment involving a special electric field apparatus, small, charged masses can be placed between two horizontal, charged, parallel plates through a tiny hole in the top plate.

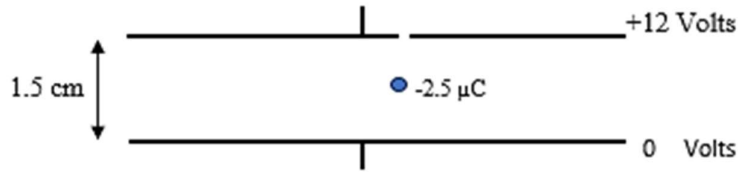

- (a) Calculate the electric field strength between the plates. **1**

.....
.....

The small charged mass is found to have a charge of $-2.5 \mu\text{C}$.

- (b) Calculate the force experienced by the charged mass due to electric field. **1**

.....
.....

- (c) The charged mass is observed to remain stationary between the plates. Determine the mass of the charged particle. **1**

.....
.....
.....

- (d) The charged mass is pushed vertically down towards the bottom plate for 0.5 cm. Calculate the work done and state where the work is done on. **2**

.....
.....
.....
.....

Question 25 (6 marks)

An electrical circuit is shown below.

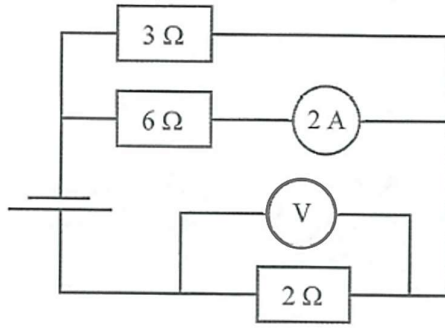

(a) Calculate the total resistance of this circuit.

2

.....

.....

.....

.....

.....

(b) Calculate the voltage across the 2 Ω resistor.

2

.....

.....

.....

.....

.....

(c) Calculate the current through the 6 Ω resistor if the 3 Ω resistor fails and does not conduct.

2

.....

.....

.....

.....

.....

Question 26 (4 marks)

The diagram below shows a solenoid. The direction of the current through the coil is shown. The length of the solenoid is 20 cm.



- (a) On the diagram above, draw the magnetic field around the solenoid. 2

- (b) Calculate the strength of the magnetic field in the solenoid's interior if 5 A of current is flowing in the wire. 2

.....

.....

.....

.....

.....

Section I

15 Marks

Attempt Questions 1 – 15

Allow about 25 minutes for this section

Use the multiple-choice answer sheet for Questions 1 –15.

- 1 Which of the following diagrams correctly shows the direction of electric field lines between two parallel charged plates? **A**

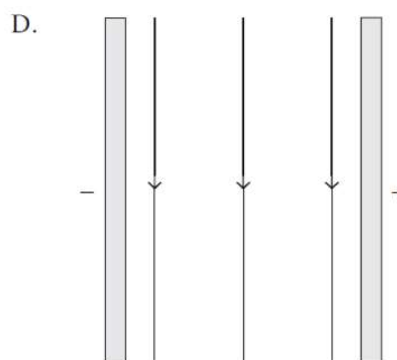
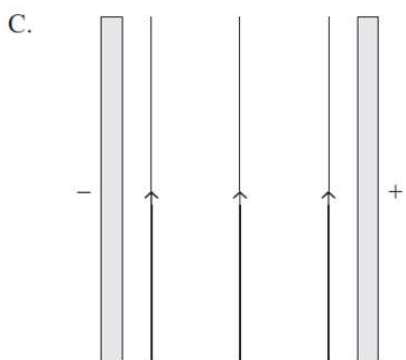
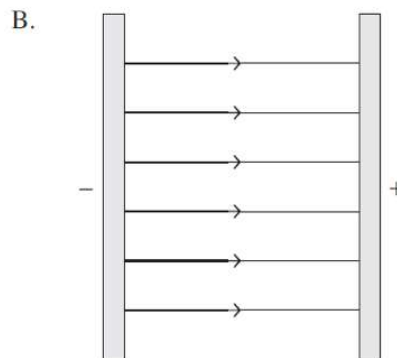
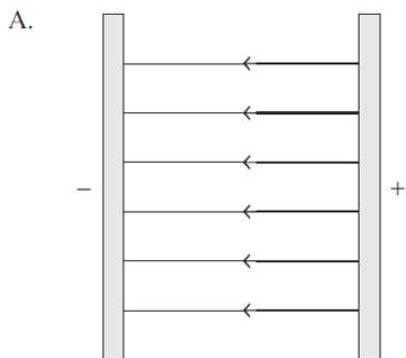

- 2 A person enters an elevator in a multi-story building and stands on a set of digital bathroom scales. The reading on the scales is 60 kg. A short while after the doors to the elevator close, the person notices that the reading on the scales is 70 kg.

This change most likely occurred because the elevator was:

- (A) travelling at a constant speed to a lower level.
- (B) travelling at a constant speed to a higher level.
- (C) accelerating to a lower level.
- (D) accelerating to a higher level.**

Since the scale is measuring a higher reading, it means that the upwards Normal force is greater than the weight force, giving a net force going upwards → the elevator is accelerating upwards.

- 3 A set of darts was used to represent the result of an investigation which was repeated four times and then an average taken.

Which is the best match for the results?

(A)

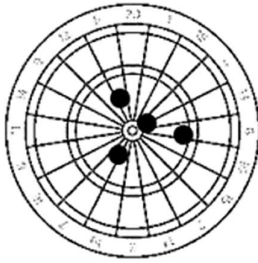

(B)

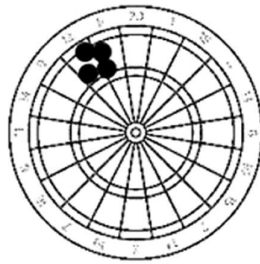

(C)

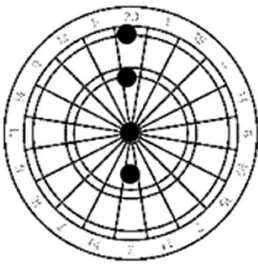

(D)

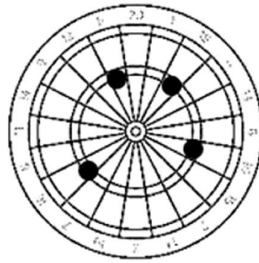

(A)

(B)

(C)

(D)

	<i>Reliability</i>	<i>Accuracy</i>
(A)	High	Low
(B)	High	Low
(C)	High	High
(D)	Low	High

- 4 Earth has a mass of 6.0×10^{24} kg. The Moon has a mass of 7.3×10^{22} kg.

Which of the following statements describes the interaction between Earth and the Moon?

Use Newton's 3rd Law.

- (A) The Earth pulls on the Moon with a force that is greater than the force that the Moon pulls on Earth.
- (B) The Moon pulls on Earth with a force that is greater than the force that Earth pulls on the Moon.
- (C) The Earth pulls on the Moon with a force of the same magnitude as the force that the Moon pulls on Earth.**
- (D) The Earth experiences a greater acceleration than the Moon because the Moon has a smaller mass.

- 5 How much energy is dissipated by a heating coil that has a resistance of 5.0Ω when a current of 6.0 A flows through it for one minute?

- (A) 30 J
 (B) 180 J
 (C) 9.0 kJ
 (D) **10.8 kJ**

$$I = \frac{q}{t}; q = It = 6(60) = 360 \text{ C}$$

$$V = IR = (6)(5) = 30 \text{ V}$$

$$W = \Delta E = qV = (360)(30) = 10800 \text{ J}$$

- 6 A negatively charged rod is held close to a metal ball suspended on a string.

What happens to the ball?

The metal ball consists of an equal number of positive and negative charges. The negative charges are delocalised electrons, hence they are mobile.

- (A) The ball is not affected by the rod as it is not touching the ball.
 (B) Positive charges in the ball move towards the right and the ball is attracted to the rod.
 (C) Negative charges in the ball move towards the right and the ball moves away from the rod.
 (D) **Negative charges in the ball move towards the left and the ball moves towards the rod.**

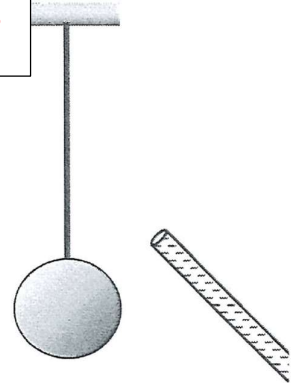

- 7 A long wire is carrying 10 A of current out of page.

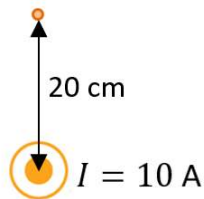

$$B = \frac{\mu_0 I}{2\pi r} = \frac{(4\pi \times 10^{-7})(10)}{(2\pi)(0.20)}$$

Then use the right-hand grip rule to find the direction of B.

Which of the following correctly shows the direction of the magnetic field due to the current as seen from the front of the page and the magnitude of the magnetic field measured 20 cm above the wire?

	Direction of magnetic field	Magnitude of magnetic field (T)
(A)	Clockwise	1.0×10^{-5}
(B)	Clockwise	5.0×10^{-5}
(C)	Anti-clockwise	1.0×10^{-5}
(D)	Anti-clockwise	5.0×10^{-5}

- 8 Two blocks of wood are pushed along a frictionless horizontal surface with a force of 200N as shown below.

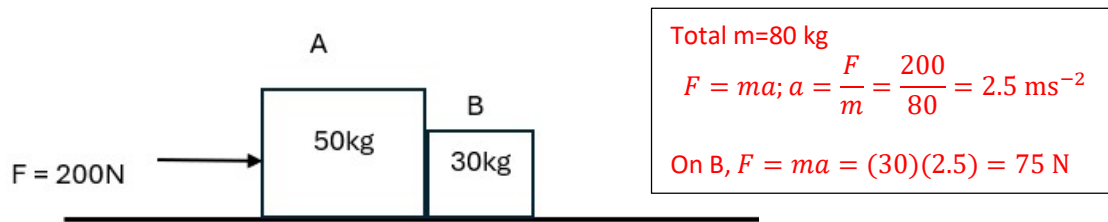

Block A has a mass of 50 kg and Block B has a mass of 30 kg.

What is the magnitude of the force exerted by Block B on Block A?

- (A) 75 N
 (B) 125 N
 (C) 200 N
 (D) 294 N
- 9 Total internal reflection in optical fibres is widely used in communication. The flexible glass fibres can bend around corners but there are limits. If the bend is too tight, light (and hence data) can be lost.

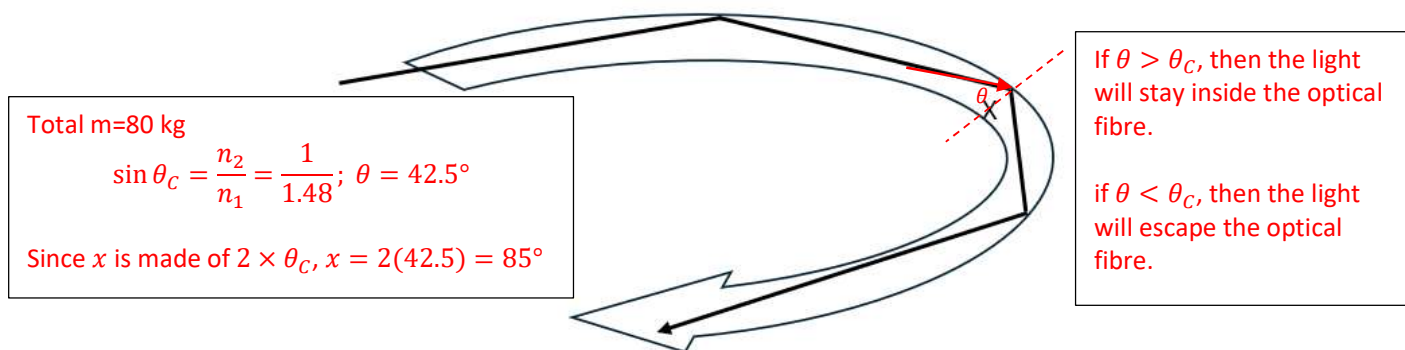

If an optical fibre has a refractive index of 1.48, at what angle (X) will light begin to escape?

- (A) $< 42.5^\circ$
 (B) $> 42.5^\circ$
 (C) $< 85^\circ$
 (D) $> 85^\circ$

- 10 Two point charges, q_1 and q_2 are separated by a distance of 4.00 cm. q_1 has a charge of $+5.00 \mu\text{C}$ while q_2 has a charge of $+8.00 \mu\text{C}$. What is the magnitude of the force exerted on q_1 by q_2 ?

- (A) 8.99 N
(B) 225 N
 (C) 2.25×10^8 N
 (D) 2.25×10^{10} N

$$F = \frac{1}{4\pi\epsilon_0} \frac{q_1 q_2}{r^2} = \left(\frac{1}{(4\pi)(8.854 \times 10^{-12})} \right) \left(\frac{(5 \times 10^{-6})(8 \times 10^{-6})}{(0.04)^2} \right)$$

- 11 A simple solenoid made by wrapping wire around a cardboard cylinder is attached to a voltage source.

Using, $B = \frac{\mu_0 NI}{L}$, if N and/or I increase, then B will also increase.

I will increase if the resistance in the wire decreases (thicker the wire = lower the resistance).

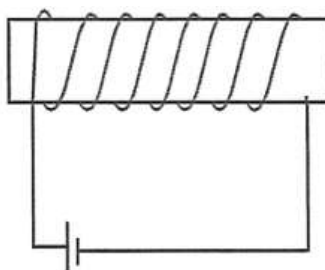

Which of the following changes would produce the greatest increase in magnetic field strength at the centre of the solenoid if the voltage supplied and the number of turns is kept constant?

- (A) Increasing the diameter of the solenoid
(B) Increasing the thickness of the wire making up the solenoid
 (C) Increasing the length of the solenoid
 (D) Using an alternating current instead of a direct current
- 12 A sound is measured to have an intensity of $7.6 \times 10^{-1} \text{ Wm}^{-2}$. The measurement was taken at a distance of 4.5 m from the source of the sound.

What is the power rating of the source?

- (A) 3.4 W
 (B) 15 W
 (C) 48 W
(D) 193 W

Deducing from the unit of intensity given in the question,

$$\text{Intensity} = \frac{\text{Power (W)}}{\text{Area (m}^2\text{)}}$$

$$\text{Therefore, Power} = I \times A = (7.6 \times 10^{-1})(4\pi \times 4.5^2) = 193 \text{ W}$$

- 13 A stationary observer sees an aeroplane flying directly towards them at a constant speed of 221 ms^{-1} . The observer hears a sound coming from the aeroplane that has a frequency of 1200 Hz as it flies towards them.

What is the frequency of the sound heard by the observer as the aeroplane flies away from them?

- (A) **255 Hz**
 (B) 420 Hz
 (C) 1980 Hz
 (D) 3430 Hz

When the plane is flying towards them:

$$v_{\text{wave}} = 340 \text{ ms}^{-1}; v_{\text{observer}} = 0; v_{\text{source}} = 221 \text{ ms}^{-1}; f' = 1200 \text{ Hz}$$

$$f' = f \frac{(v_{\text{wave}} + v_{\text{observer}})}{(v_{\text{wave}} - v_{\text{source}})}$$

$$f = 1200 \frac{(340 - 221)}{(340)} = 420 \text{ Hz}$$

When the plane is flying away from them:

$$v_{\text{wave}} = 340 \text{ ms}^{-1}; v_{\text{observer}} = 0; v_{\text{source}} = -221 \text{ ms}^{-1}; f = 420 \text{ Hz}$$

$$f' = f \frac{(v_{\text{wave}} + v_{\text{observer}})}{(v_{\text{wave}} - v_{\text{source}})} = 420 \frac{340}{(340 + 221)} = 255 \text{ Hz}$$

- 14 A 3 kg mass moves at a velocity of 0.4 ms^{-1} on a frictionless surface and collides with a stationary mass (1.5 kg). The velocity and direction of the 3 kg mass before and after the collision, are shown in the diagram below (viewed from above).

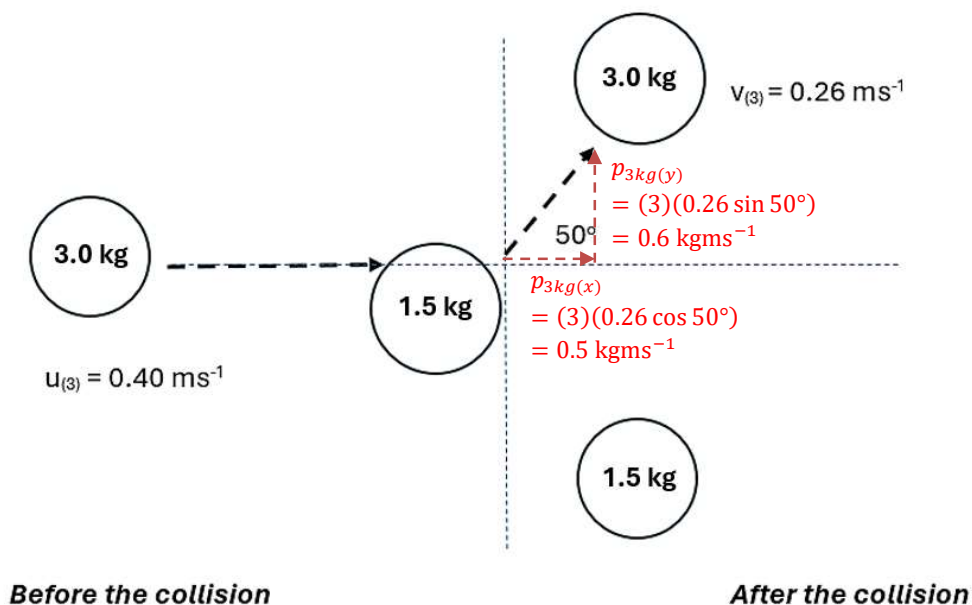

What is the momentum of the 1.5 kg mass after the collision?

- (A) 0.61 kgm^{-1}
 (B) 0.78 kgm^{-1}
 (C) **0.92 kgm^{-1}**
 (D) 1.20 kgm^{-1}

Momentum before: $p_{\text{initial}} = (3)(0.4) = 1.2 \text{ kgms}^{-1}$

Momentum after of 1.5 kg mass:

Vertical component:

$$p_y = -(3)(0.26 \sin 50^\circ) = 0.6 \text{ kgms}^{-1} \text{ downwards}$$

Horizontally:

$$p_x = 1.2 - (3)(0.26 \cos 50^\circ) = 0.7 \text{ kgms}^{-1} \text{ to the right}$$

Adding the two components:

$$p_{1.5\text{kg}} = \sqrt{0.6^2 + 0.7^2} = 0.92 \text{ kgms}^{-1}$$

- 15 During a daring acrobatic performance at a circus, one acrobat is standing on the shoulders of another acrobat. A third person, dressed as a clown, is projected 3 metres upwards onto the shoulders of the top person, when a fourth person jumps down from a box that is 1.5 metres in height, onto a device that propels the clown upwards.

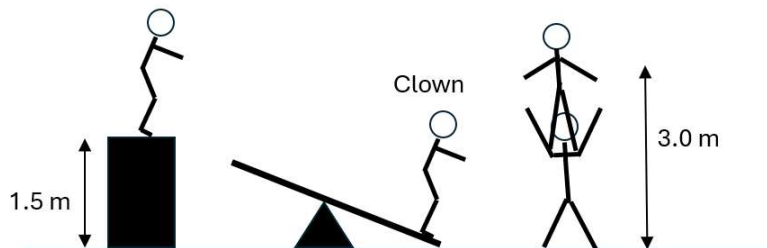

What is the approximate mass of the person who jumps from the box if the clown has a mass of 45 kg?

- (A) 45 kg
- (B) 60 kg
- (C) 80 kg
- (D) **100 kg**

When the clown reaches the acrobat's shoulders at 3 m height, the clown has the GPE.
The clown's GPE at 3 m, comes from the GPE of the person who jumps from the box.

$$\begin{aligned}GPE_{\text{person on box}} &= GPE_{\text{clown}} \\m_{\text{person on box}}(9.8)(1.5) &= (45)(9.8)(3) \\m_{\text{person on box}} &= 90 \text{ kg}\end{aligned}$$

End of Section I

Question 16 (4 marks)

Two trucks (A and B) are travelling along separate roads at constant speed towards an intersection as shown in the diagram below. Both trucks are travelling at 25 ms^{-1} . One road is North-South, and the other is East-West. The North-South road passes over the top of the East-West road.

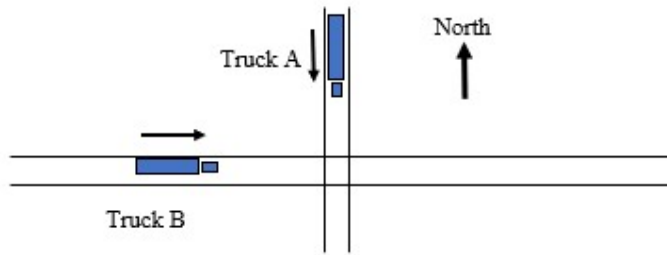

- (a) Draw a vector diagram that shows the velocity of truck B with respect to truck A. State the magnitude and the direction of the velocity of truck B with respect to truck A on the diagram. 2

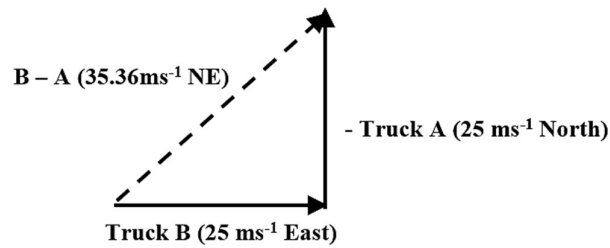

Criteria	Marks
<ul style="list-style-type: none"> Student has correctly constructed a diagram representing both trucks' direction and the relevant vector. AND Correct statement of direction and magnitude of velocity. 	2
<ul style="list-style-type: none"> Mistake in calculation OR Error in diagram 	1

Marker's comments:

- Sig. figs need to be discussed about convention
- Flipping of Truck A velocity common mistake

- (b) Calculate the displacement of truck A with respect to truck B, 20 seconds after they simultaneously pass over/under each other. 2

$$\begin{aligned} \text{Displacement of } A &= v_A \times t = 500 \text{ m South} \\ \text{Displacement of } B &= v_B \times t = 500 \text{ m East} \\ \therefore \text{Displacement of } A + (-B) &= 707 \text{ m SW} \end{aligned}$$

Criteria	Marks
<ul style="list-style-type: none"> Correct magnitude stated. Correct direction stated 	2
<ul style="list-style-type: none"> Missing one of the criteria 	1

Marker's comments:

- Direction seems to be most common mistake, need to be careful and understand where the relevant vectors are going.

Question 17 (3 marks)

The diagram shows two square wave pulses travelling towards each other. Each pulse is moving at a speed of 1.5 ms^{-1} .

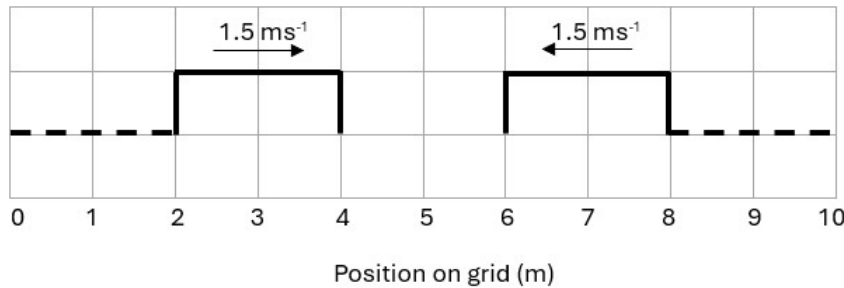

(a) Complete the diagram below to show what these pulses look like 1.0 s later.

2

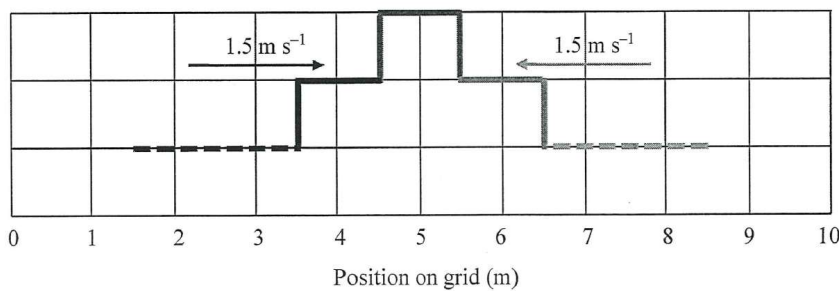

Criteria	Marks
<ul style="list-style-type: none"> • Correct uptick between 3 & 4 and 6 & 7. • Correct uptick between 4 & 5 and 5 & 6. 	2
<ul style="list-style-type: none"> • Missing one of the criteria • OR • Mistake in drawing 	1

Marker's comments:

- This is basic wave behaviour; it should be free marks.

(b) Identify the name of the wave principle that determine the result when two waves overlap in a medium.

1

Wave superposition

Marker's comments:

- Interference (constructive or destructive) is not a wave principle, it is the result of wave superposition.

Question 18 (6 marks)

The velocity vs time graph for an object travelling in a straight line on a horizontal surface is shown below.

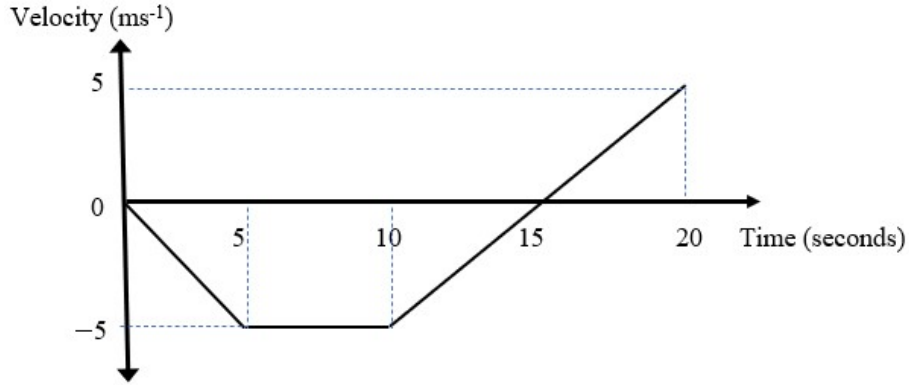

- (a) Quantitatively describe the motion of the object during the first 10 seconds. 2

*0-5 seconds constant negative acceleration from rest of 1 ms^{-2} (backwards)
5-10 seconds constant negative velocity of 5 ms^{-1} for 5 seconds (backwards)*

Criteria	Marks
<ul style="list-style-type: none"> Stated between 0-5 seconds that the vehicle undergoes negative 1 m/s^2 of acceleration Stated between 5-10 seconds acceleration is zero and constant velocity of -5 m/s 	2
<ul style="list-style-type: none"> Missing one of the criteria 	1

Marker's comments:

- Question says quantitatively, answer needs quantities. Need values in your description.

- (b) Calculate the distance travelled by the object between 10 and 20 seconds. 2

*Distance travelled between 10 and 15 seconds is $\frac{1}{2} \times 5 \times 5 = 12.5 \text{ m}$
Distance travelled between 15 and 20 seconds is $\frac{1}{2} \times 5 \times 5 = 12.5 \text{ m}$
Total distance travelled is 25 m .*

Criteria	Marks
<ul style="list-style-type: none"> Using the area under the graph, calculates 25 m 	2
<ul style="list-style-type: none"> Incorrect substitution into calculation 	1

- (c) In the space below, draw a displacement vs time graph for the motion of the object over the 20 second period. 2

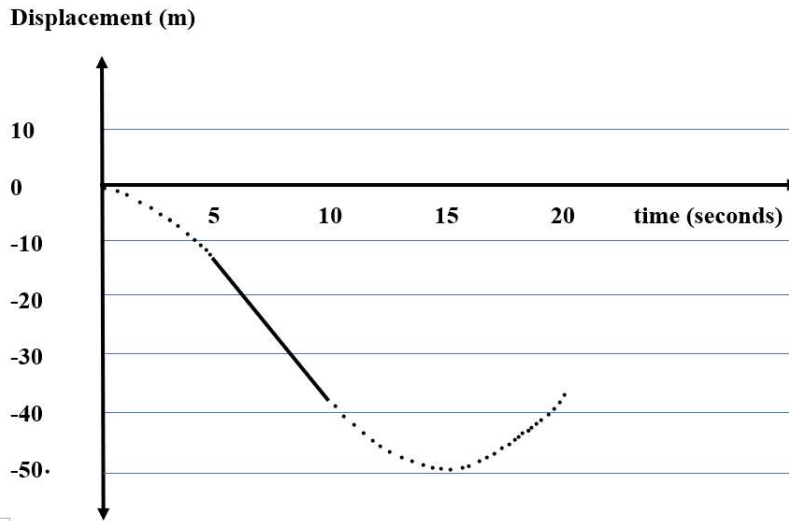

Criteria	Marks
<ul style="list-style-type: none"> • Correctly graphs straight line between (5,-11) to (10,-38) • Correctly graphs curves before and after the straight line 	2
<ul style="list-style-type: none"> • Missing one of the criteria 	1

Question 19 (5 marks)

Two people go fishing. At the beginning of the day, they launch the boat (mass = 1200 kg) at a boat ramp by allowing the boat to slide freely off the boat trailer into the water. The boat ramp has an angle of 10° .

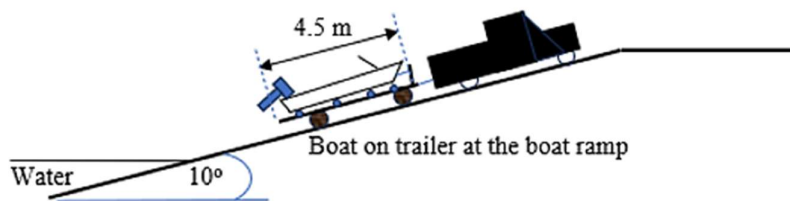

- (a) Assuming that the rollers on the trailer has no resistance to the movement of the boat, calculate the acceleration of the boat before it enters the water. **1**

$$a = g \sin \theta = 9.8 \times \sin 10^\circ = 1.7 \text{ ms}^{-2}$$

The boat will move with a constant acceleration of 1.7 ms^{-2} down the trailer.

Criteria	Marks
<ul style="list-style-type: none"> • Correctly calculates the acceleration. 	1

- (b) After fishing, an electric winch is used to pull the boat back onto the trailer at the same boat ramp. If the winch moves the centre of gravity of the boat through a distance of 2.25 metres in 8 seconds when pulling the boat onto the boat trailer, determine the minimum power that the winch provides. **2**

$$P = \frac{W}{t} = \frac{Fs}{t} = \frac{mg \sin \theta \cdot s}{t} = \frac{1200 \times 9.8 \times \sin 10^\circ \times 2.25}{8} = \frac{4594.73}{8} = 574.3 \text{ W}$$

Criteria	Marks
• Using Force, calculates the power of the winch	2
• Incorrect substitution into formula	1

- (c) Before the boat is towed away on a trailer, it is secured by a chain that prevents it from rolling backwards. Draw a labelled diagram to show how the forces that act on the boat are balanced, while it is on the trailer on the ramp and held by the chain. 2

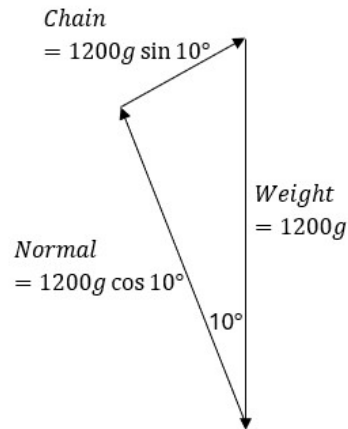

Criteria	Marks
• Student shows how both the x and y axis are balanced on the boat.	2
• Student is missing either a value or relevant = to balance both the x and y axis.	1

Marker's comments:

- Lots of students needed to simply add values to get full marks

Question 20 (5 marks)

When investigating the effectiveness of crumple zones on the front of motor vehicles, collisions between test crash vehicles and concrete barriers provide valuable information about safety features of cars and trucks.

The graph below represents the force on the front of a test crash car ($m = 2000$ kg) from the time it runs into a concrete crash barrier and when it stops.

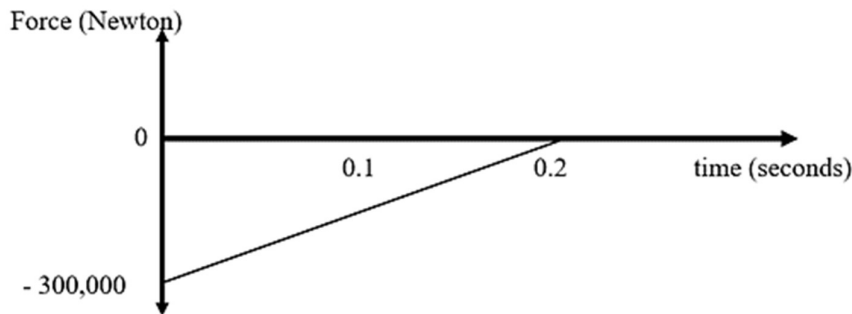

- (a) Calculate the maximum acceleration of the test crash car. 1

$$a(\text{max}) = \frac{F(\text{max})}{m} = \frac{300000}{2000} = 150 \text{ ms}^{-2}$$

Criteria	Marks
<ul style="list-style-type: none"> Correctly calculates the acceleration 	1

- (b) Calculate the speed that the test car was travelling, immediately before it hit the concrete wall. 2

$$\Delta p = F \Delta t \text{ (area under graph)} = 0.5 \times 300\,000 \times 0.2 = 30\,000 \text{ kgms}^{-1}$$

$$\Delta p = m\Delta v, \text{ so } \Delta v = \Delta p/m = 30\,000/2000 = 15 \text{ ms}^{-1}$$

Since the final velocity was zero, the impact speed was 15 ms^{-1} .

Criteria	Marks
<ul style="list-style-type: none"> Student uses impulse equation and area under graph to calculate speed. 	2
<ul style="list-style-type: none"> Incorrect substitution into equation leading to error in answer. 	1
<ul style="list-style-type: none"> Use of acceleration to find answer 	0

Marker's comments:

- Acceleration is not given in the question, so SUVATs do not work. The previous question worked out maximum acceleration.

- (c) Is the collision elastic or inelastic? Explain why. 2

The initial KE of the car before the collision was $= \frac{1}{2} mv^2 = 0.5 \times 2000 \times 15^2 = 225000 \text{ J}$.

After the collision, the car had zero speed and therefore, zero KE.

Hence, all KE was lost in the collision. Therefore, the collision was inelastic.

Criteria	Marks
<ul style="list-style-type: none"> Student has justified their decision on the change in Kinetic Energy by comparing Velocities. Determined the collision is inelastic 	2
<ul style="list-style-type: none"> Missing one of the criteria 	1

Question 21 (4 marks)

An object is placed between the principal focus, f , and the centre of curvature, C , of the concave mirror, as shown in the diagram below.

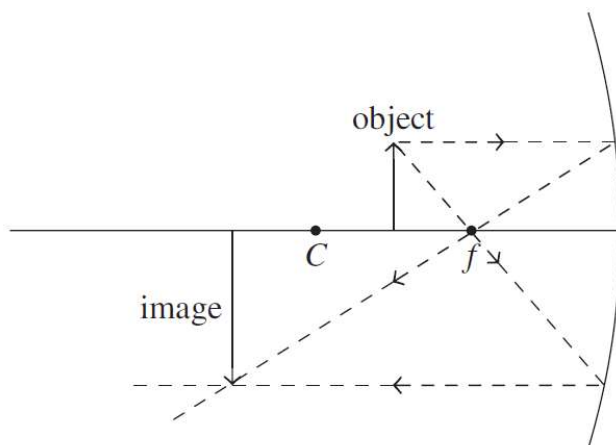

- (a) On the diagram above, draw rays to show the location of the image produced. 2

Criteria	Marks
• Student correctly draws TWO rays that reflect to determine the correct image	2
• The student correctly draws ONE ray that reflects	1

Marker's comments:

- Some real monstrosities came out of this question
- Question says mirror so why did some draw through the diagram

- (b) Identify the nature of the image 2

The image produced is enlarged, inverted and real.

Criteria	Marks
• Student correctly interprets their diagram (if possible) with three qualities	2
• Student correctly interprets their diagram (if possible) with 2 qualities	1

Question 22 (6 marks)

A person produces a list of the steps they used to make a cup of coffee.

1. Place 500 mL of clean tap water (at 20°C) into an empty electric kettle.
2. Turn on the kettle and wait for it to boil.
3. Pour 200 mL of boiling water (at 100°C) into a porcelain mug (at 20°C) containing a small amount of instant coffee.
4. Stir gently with a spoon for 10 seconds.

- (a) If it takes 1 minute and 35 seconds for the 500 mL of water to boil, calculate the minimum effective power of the electric kettle. 1

$$P = E/t = (mC\Delta T) / t = (500 \times 4.18 \times 80) / 95 = 1760 \text{ W}$$

- (b) If the porcelain mug has a specific heat capacity of 1100 Jkg⁻¹C⁻¹ and a mass of 340 g, determine the maximum temperature of the coffee after the mug and the coffee (i.e. water) have reached thermal equilibrium (assume there are no heat losses to the surroundings while thermal equilibrium is being reached). 3

$$\begin{aligned} \text{Heat gained by the mug} &= \text{heat lost by the coffee (water)} \\ Q(\text{mug}) &= Q(\text{coffee}) \\ m(\text{mug}) \times C(\text{mug}) \times \Delta T(\text{mug}) &= m(\text{coffee}) \times C(\text{coffee}) \times \Delta T(\text{coffee}) \\ 0.340 \times 1100 \times (T - 20) &= 0.200 \times 4180 \times (100 - T) \\ 374T - 7480 &= 83600 - 836T \\ 1210T &= 91080 \\ T &= 75.3 \text{ }^\circ\text{C} \end{aligned}$$

Criteria	Marks
• Equates 'heat gained by mug = heat lost by coffee' using $q = mC\Delta T$	3
• Substitutes correct expression for ΔT	
• Solves the equation without errors to find $T(\text{final})$.	
• Missing any one of above	1

Marker's comments:

- Poorly answered.
- Those who equated that $Q(\text{mug}) = Q(\text{coffee})$, not many then used the correct expression for ΔT or made simple algebraic errors in their calculation.

- (c) The student noticed that the temperature of the coffee decreased slightly when the coffee was stirred with a metal spoon. 2
Provide a thermodynamic explanation for why this temperature change occurred.

The temperature of the coffee became slightly lower because the spoon was colder than the coffee. Some heat from the coffee was transferred to the colder metal spoon by conduction.

Criteria	Marks
<ul style="list-style-type: none">• States the cause: heat transfers by conduction from a warmer to a colder object (i.e. from hot coffee to spoon)• States the effect: objects achieve thermal equilibrium, hot coffee becomes cooler and the spoon gets warmer	2
<ul style="list-style-type: none">• Response lacks details (e.g. The spoon absorbed heat from the coffee and caused the coffee to decrease in temperature.)	1

Marker's comments:

- Generally well answered.

Question 23 (6 marks)

A student conducts an experiment to measure the electrostatic force between two identical, charged objects at various distances. Data obtained from the experiment is shown in the table below.

Data point	Distance (m)	$1/\text{distance}^2$ (m^{-2})	Electrostatic force (N)
1	0.03	1110	40.0
2	0.04	625	22.5
3	0.05	400	14.5
4	0.06	278	10.0

- (a) Using data point 1, calculate the magnitude of the charge on each object. 2

$$F = \frac{1}{4\pi\epsilon_0} \frac{q_1 q_2}{r^2}$$
$$40 = \frac{1}{4\pi(8.854 \times 10^{-12})} \frac{q^2}{0.03^2}$$
$$q^2 = 40 \times 4\pi(8.854 \times 10^{-12}) \times 0.03^2$$
$$q = \sqrt{4.00 \times 10^{-12}}$$
$$\therefore q = 2 \times 10^{-6} \text{ C}$$

Criteria	Marks
<ul style="list-style-type: none">• Uses the correct formula and correct substitution of data shown clearly• Identifies that q_1 and q_2 are equal, hence works out q by square rooting the value.	2
<ul style="list-style-type: none">• Any one error in calculation	1

Marker's comments:

- Generally well answered but some divided the value of q_1q_2 by 2 instead of square rooting it.

(b) Plot the data points on the axes provided. Include a trendline.

2

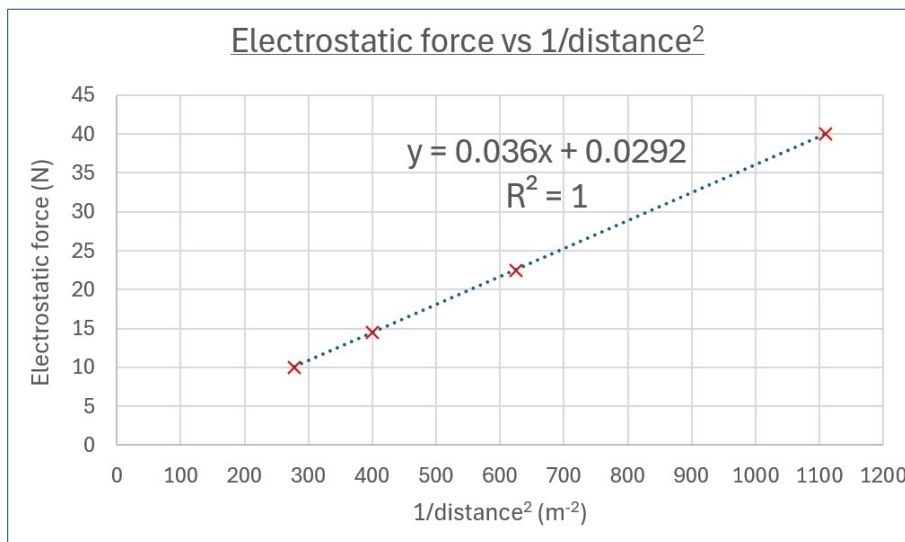

Criteria	Marks
<ul style="list-style-type: none"> • Appropriate scales on each axis • Correctly plots all data points and draws a trendline to suit the plotted points 	2
<ul style="list-style-type: none"> • Any one error 	1

(c) Use the gradient of the trendline in (b) to determine the value of the electric permeability constant, ϵ_0 .

2

$$\text{gradient} = \frac{q_1q_2}{4\pi\epsilon_0} = 0.036$$

$$0.036 = \frac{(2 \times 10^{-6})^2}{4\pi\epsilon_0}$$

$$\epsilon_0 = \frac{(2 \times 10^{-6})^2}{0.036 \times 4\pi}$$

$$\epsilon_0 = 8.842 \times 10^{-12}$$

Criteria	Marks
<ul style="list-style-type: none"> • Correctly determines the gradient of the trendline drawn in (b) • Uses the value of the gradient to determine the value of ϵ_0 	2
<ul style="list-style-type: none"> • Any one error 	1

Marker's comments:

- Poorly answered.
- Many were able to find the gradient of the line, however only a few then used it to find the ϵ_0 value.

Question 24 (5 marks)

In an experiment involving a special electric field apparatus, small, charged masses can be placed between two horizontal, charged, parallel plates through a tiny hole in the top plate.

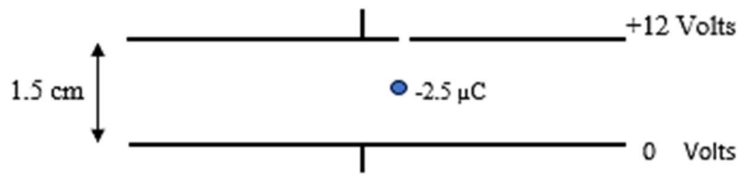

- (a) Calculate the electric field strength between the plates.

1

$$E = V/d = 12/0.015 = 800 \text{ NC}^{-1}$$

Criteria	Marks
• Correctly calculates E using the right formula	1

The small charged mass is found to have a charge of $-2.5 \mu\text{C}$.

- (b) Calculate the force experienced by the charged mass due to electric field.

1

$$F_E = Eq = 800 \times (2.5 \times 10^{-6}) = 0.002 \text{ N upwards}$$

Criteria	Marks
• Correctly calculates F using the right formula including the direction	1

Marker's comments:

- Many did not specify the direction of F .

- (c) The charged mass is observed to remain stationary between the plates. Determine the mass of the charged particle.

1

$$\begin{aligned} F_E &= F_W \\ 0.002 &= m(9.8) \\ m &= 2.04 \times 10^{-4} \text{ kg} \end{aligned}$$

Criteria	Marks
• Equates $F_E = F_W$ to find the mass of the particle.	1

Marker's comments:

- Poorly answered as not many recognised that $F_E = F_W$ when the mass is levitated between the plates

- (d) The charged mass is pushed vertically down towards the bottom plate for 0.5 cm. Calculate the work done and state where the work is done on.

2

$$\begin{aligned} W &= Fd = qEd = (2.5 \times 10^{-6})(800)(0.005) = 1.0 \times 10^{-5} \text{ J} \\ &\text{This work is done on the field.} \end{aligned}$$

Criteria	Marks
• Correctly calculates W AND • States that the work is done on the field	2

Marker's comments:

- Not many correctly stated where the work is done on.

Question 25 (6 marks)

An electrical circuit is shown below.

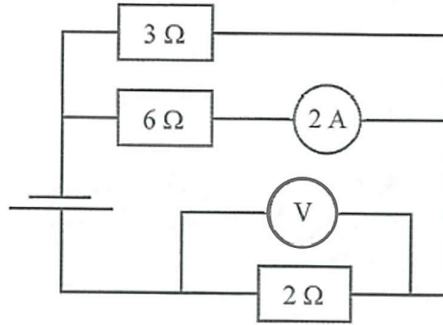

(a) Calculate the total resistance of this circuit.

2

$$\frac{1}{\text{parallel R}} = \frac{1}{3} + \frac{1}{6}$$

$$\frac{1}{\text{parallel R}} = \frac{2}{6} + \frac{1}{6} = \frac{3}{6}$$

$$\text{parallel R} = \frac{6}{3} = 2 \Omega$$

$$\text{Total R of circuit} = \text{series R} + \text{parallel R} = 2 + 2 = 4 \Omega$$

Criteria	Marks
<ul style="list-style-type: none"> • Correctly calculates the resistance in the parallel circuit AND	2
<ul style="list-style-type: none"> • Adds this with the resistor connected in series, 2 Ω, to find the total resistance 	
OR	1
<ul style="list-style-type: none"> • Any 1 error in calculation 	

(b) Calculate the voltage across the 2 Ω resistor.

2

$$\text{Current in } 3 \Omega \text{ resistor} = 2 \times \text{current in } 6 \Omega = 4 \text{ A}$$

$$\text{Total current in } 2 \Omega \text{ resistor} = 4 + 2 = 6 \text{ A}$$

$$\text{Voltage across } 2 \Omega \text{ resistor} = I R = 6 \times 2 = 12 \text{ V}$$

Criteria	Marks
<ul style="list-style-type: none"> • Correctly calculates the total current in the circuit (6 A) AND	2
<ul style="list-style-type: none"> • Recognises that the total current (6 A) flows through 2 Ω resistor to work out the voltage across it 	
<ul style="list-style-type: none"> • Any 1 error in calculation 	1

- (c) Calculate the current through the $6\ \Omega$ resistor if the $3\ \Omega$ resistor fails and does not conduct. 2

Voltage of battery = total resistance \times circuit current in $2\ \Omega = 4 \times 6 = 24\ \text{V}$

Voltage of battery does not change if $3\ \Omega$ blows but circuit resistance is now $2 + 6 = 8\ \Omega$

Circuit current = $\frac{V}{R} = 3\ \text{A} =$ current through $6\ \Omega$ resistor.

Criteria	Marks
<ul style="list-style-type: none"> Correctly calculates the total voltage provided by the cell ($24\ \text{V}$) AND	2
<ul style="list-style-type: none"> Recognises that the total resistance is now $8\ \Omega$ to work out the current through $6\ \Omega$ resistor 	
<ul style="list-style-type: none"> Any 1 error in calculation 	1

For all parts in Q25, no marks were awarded for coincidentally getting the right value. Conceptual understanding and the ability of using Kirchoff's laws for series and parallel circuits needed to be demonstrated in the working out to possibly obtain a mark.

Question 26 (4 marks)

The diagram below shows a solenoid. The direction of the current through the coil is shown. The length of the solenoid is $20\ \text{cm}$.



- (a) On the diagram above, draw the magnetic field around the solenoid. 2

Criteria	Marks
<ul style="list-style-type: none"> Correctly drawn magnetic field lines around the solenoid (lines must be connected to the solenoid) AND	2
<ul style="list-style-type: none"> The magnetic lines drawn need to be symmetrical and have arrowheads pointing in the right direction 	
<ul style="list-style-type: none"> Missing any one of above 	1

No marks for identifying N and S end on the solenoid

- (b) Calculate the strength of the magnetic field in the solenoid's interior if $5\ \text{A}$ of current is flowing in the wire. 2

$$B = \frac{\mu_0 NI}{L} = \frac{(4\pi \times 10^{-7})(10)(5)}{(0.2)} = 3.14 \times 10^{-4} = 3 \times 10^{-4}\ \text{T}$$

Criteria	Marks
<ul style="list-style-type: none"> Correctly calculates B using the correct formula AND	2
<ul style="list-style-type: none"> Shows correct substitution including that $N = 10$ (not 9) and $L = 0.2$ (not 20) 	
<ul style="list-style-type: none"> Missing any one of above 	1

Penalised for not rounding the final answer to one significant figure.

Question 27 (6 marks)

Compare the production of magnetic fields in solenoids and permanent magnets.
(Include labelled diagrams in your answer).

A solenoid is a coil of wire. A magnetic field is produced in the coil only when a current travels through the wires. Thus, it is a temporary magnet (i.e. an electromagnet).

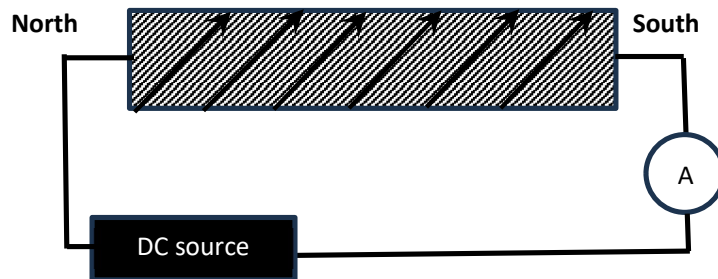

When a direct current is travelling through the solenoid, the shape of the field is similar to the shape of the field produced by a permanent magnet, hence it has a north and a south pole, with the magnetic field going from a north to a south pole around it and from a south to a north inside it.

Permanent magnets are produced in ferromagnetic materials by aligning tiny magnetic domains in the same direction. Once aligned, the combined effect of the magnetic domains produces a strong and stable magnetic field (see diagrams below).

Ferromagnetic material with domain field directions randomly arranged.

No net magnetic field.

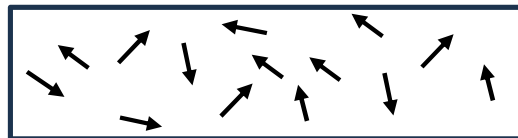

Ferromagnetic material with domain fields aligned in the same direction.

Strong permanent field

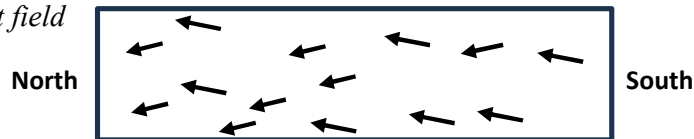

The differences between the two types of magnets are that an electromagnet requires a current flow in the coiled wire to act as a magnet and the strength of the magnetic field can be adjusted by varying the amount of current, the number of loops per unit length and by inserting a soft iron core in the centre. A permanent magnet on the other hand does not require current (it will always produce magnetic field) and the strength of the magnetic field is constant except that it may become weaker over time.

Criteria	Marks
<ul style="list-style-type: none"> • Describes how a solenoid could produce magnetic field and states that when it does, it acts as a <i>temporary magnet</i> (it only produces magnetic field when current is flowing in the coiled wire) (t) • Describes what makes a material a permanent magnet (it's a <i>ferromagnetic material</i> with small magnetic domains within the material aligned in the same direction) (p) • Descriptions of the two types of magnets include at least one difference between the two, such as that an electromagnet acts as a temporary magnet and the strength of the magnetic field can be varied, while the other produces permanent magnetic field where its strength cannot be altered (diff) • States that both an electromagnet and a permanent magnet produces magnetic fields that are very similar, going from a north to a south and they are both bipolar (sim) • Draws a diagram to show the magnetic field around an electromagnet including the current flow (dt) • Draws a diagram to show the magnetic field around a permanent magnet (dp) 	6
<ul style="list-style-type: none"> • Missing any one of above 	5 – 1

End of Section II

End of Examination