

Student Number								
----------------	--	--	--	--	--	--	--	--

## 2023 YEAR 11 YEARLY EXAMINATION

# Physics

---

### General Instructions

- Reading time – 5 minutes
- Working time – 2 hours
- Write using black pen
- Draw diagrams using pencil
- Calculators approved by NESA may be used

---

### Total Marks:

75

### Section I – 20 marks (pages 2–10)

- Attempt Questions 1–20
- Allow about 35 minutes for this section

### Section II – 55 marks (pages)

- Attempt questions 21–33
- Allow about 1 hours and 25 minutes for this section

## Section I

20 marks

Attempt Questions 1–20

Allow about 35 minutes for this section

Use the multiple-choice answer sheet for Questions 1–20.

---

1. A concave lens is shown.

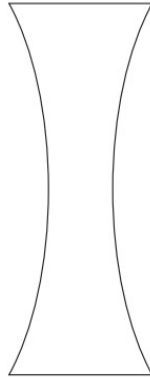

Which of the following statements about concave lenses is true?

- A. They can only form virtual images.
  - B. They can only form enlarged, inverted images.
  - C. They can only reflect incident light rays, not refract them.
  - D. They can form both virtual and real images, depending on the location of the object.
2.  $1 \text{ kWh}^{-1}$  is equivalent to 3.6 MJ.
- How much energy would be used if a  $2000 \text{ Wh}^{-1}$  hairdryer were left switched on for 2.5 hours?
- A. 7.2 MJ
  - B. 9.0 MJ
  - C. 18 MJ
  - D. 36 MJ
3. A 2.0 kg ball is held at rest in the air above a flat surface, giving the ball 14.7 J of gravitational potential energy.
- How far above the flat surface is the ball being held?
- A. 7.5 m
  - B. 29 m
  - C. 75 cm
  - D. 90 cm

4. The first harmonic for a pipe that is closed at one end, such as a didgeridoo, will have one pressure node (N) and one pressure antinode (A), as shown in the diagram.

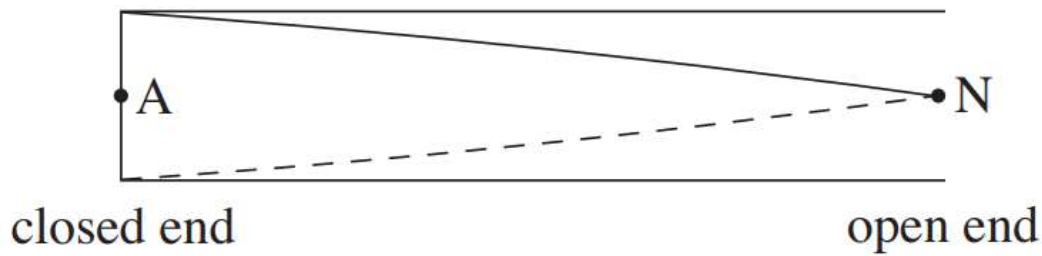

How many pressure nodes must there be for the third harmonic?

- A. 1  
 B. 2  
 C. 3  
 D. 4
5. In a Hydrogen atom, there is a single proton with a single electron orbiting. If the radius of an electron's orbit around a proton is  $5.3 \times 10^{-11}$  m, what is the strength of the electric field acting on the electron during its orbit?
- A.  $27 \text{ N C}^{-1}$   
 B.  $54 \text{ N C}^{-1}$   
 C.  $5.1 \times 10^{11} \text{ N C}^{-1}$   
 D.  $1.0 \times 10^{12} \text{ N C}^{-1}$
6. Consider the electric circuit shown. Each resistor has the same amount of resistance.

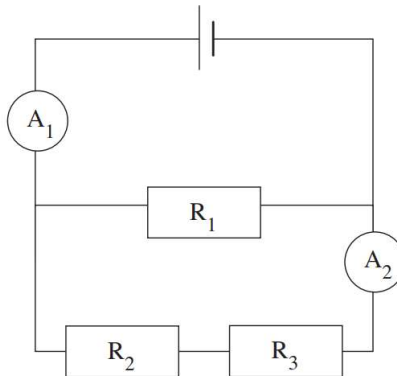

If the circuit operates with a constant voltage supply, which of the following statements is correct?

- A. Ammeter  $A_2$  measures a higher current than ammeter  $A_1$ .  
 B. Resistor  $R_1$  has a higher voltage drop than resistors  $R_2$  or  $R_3$ .  
 C. Resistors  $R_2$  and  $R_3$  have a higher combined voltage drop than resistor  $R_1$ .  
 D. The total resistance in the circuit would increase by a third if resistor  $R_3$  was removed.

7. A box is accelerating down an inclined plane.

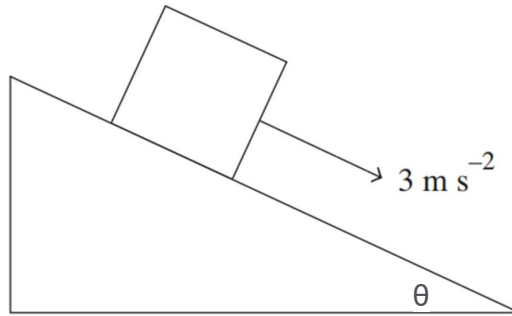

The magnitude of the friction force is half the magnitude of the normal force acting on the box. If the angle  $\theta$  is known, the magnitude of the net force acting on the box can be determined completely by

- A. calculating half the magnitude of the normal force.
  - B. calculating the component of the box's weight acting down the inclined plane.
  - C. calculating the component of the box's weight acting down the inclined plane, then subtracting half the magnitude of the normal force.
  - D. subtracting the magnitude of the box's weight from the magnitude of the normal force.
8. A and B are two charged spheres. Initially, the spheres are at a distance of  $r$  metres apart. Each sphere has a charge of  $q$  Coulombs. There is a repulsive force of  $F$  Newtons between them. The distance between the two spheres is then increased to  $2r$ . The charge on sphere A changes to  $0.6q$  C, and the charge on sphere B remains the same.

What is the new magnitude of the repulsive force between the spheres?

- A.  $0.09F$  N
  - B.  $0.15F$  N
  - C.  $0.30F$  N
  - D.  $1.00F$  N
9. A surfer times the period of the waves arriving at the beach at  $7.5$  s and estimates the wavelength to be  $55$  m. The velocity of the waves is nearest to
- A.  $0.136 \text{ m s}^{-1}$
  - B.  $41.3 \text{ m s}^{-1}$
  - C.  $13.6 \text{ m s}^{-1}$
  - D.  $7.33 \text{ m s}^{-1}$

10. Two positive charges of magnitude  $Q$  and  $2Q$  are equidistant from point  $P$ .

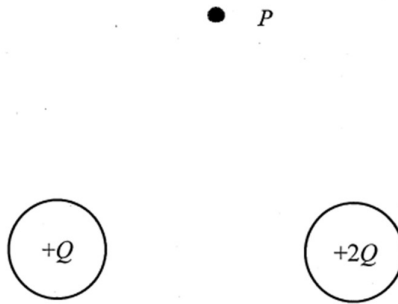

Which vector best represents the direction of the electric field at point  $P$ ?

- A.
- B.
- C.
- D.

11. The refractive index of a transparent plastic is 1.98 and the refractive index of a liquid is 1.12. The critical angle for total internal reflection of light in the plastic when it is immersed in the liquid is nearest to

- A.  $0.57^\circ$
- B.  $34^\circ$
- C.  $1.77^\circ$
- D.  $0.99^\circ$

12. A dust particle with 22 excess electrons is subjected to an electric force of  $2.56 \times 10^{-13}$  N when it is between two parallel metal plates separated by 8.0 mm. The voltage applied to the plates will be nearest to

- A. 73 V
- B. 704 V
- C. 582 V
- D. 2.8 V

13. A satellite of mass 1850 kg has a manoeuvring rocket motor which can provide 30 N of thrust. If the rocket motor is fired for 17 s, the change in velocity of the satellite will be nearest to

- A.  $0.28 \text{ m s}^{-1}$
- B.  $0.55 \text{ m s}^{-1}$
- C.  $2.34 \text{ m s}^{-1}$
- D.  $3.63 \text{ m s}^{-1}$

14. A photo of a small section of the night sky showing two very bright stars (A and B) is shown. Measurements of the spectra of the two stars show that they are actually of equal size, temperature and brightness.

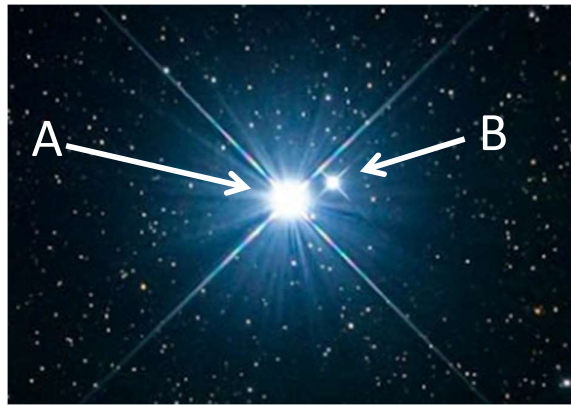

In the photo, Star A appears to be 4 times brighter than Star B.

If the distance to Star A is known to be 4.5 light years, the approximate distance to Star B in light years is

- A) 9.0
- B) 18.0
- C) 20.25
- D) 81.0

15. The diagram shows a simple experiment done by a student in a physics class.

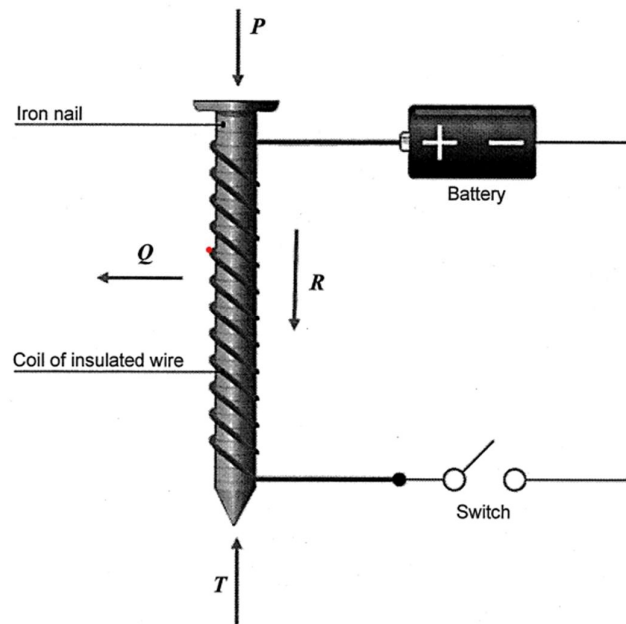

Which of the arrows correctly indicates the direction of the magnetic field at their locations when the switch is closed?

- A.  $P$  only
- B.  $T$  only
- C.  $P$  and  $Q$
- D.  $T$  and  $R$

16. Conservation laws underpin Kirchhoff's current and voltage laws.

If Kirchhoff's current law was not applicable, it would mean that:

- A. there would be higher voltages measured around a circuit than the supplied EMF.
- B. the creation or destruction of electrons would occur.
- C. electrons would flow around the circuit in one direction only.
- D. the electric circuit would have higher resistance.

17. How much energy would need to be transferred to 140 L of water to raise its temperature from  $20^{\circ}\text{C}$  to  $65^{\circ}\text{C}$ ?

- A.  $2.6 \times 10^4 \text{ J}$
- B.  $1.9 \times 10^5 \text{ J}$
- C.  $1.2 \times 10^7 \text{ J}$
- D.  $2.6 \times 10^7 \text{ J}$

18. Two toy cars have a race over a 100 m straight track. Car A starts from rest with a constant acceleration of  $2.0 \text{ m s}^{-2}$ . Car B starts 5.0 s after car A but has a constant speed of  $20 \text{ m s}^{-1}$ .

Select the graph that correctly depicts the motion of the two cars.

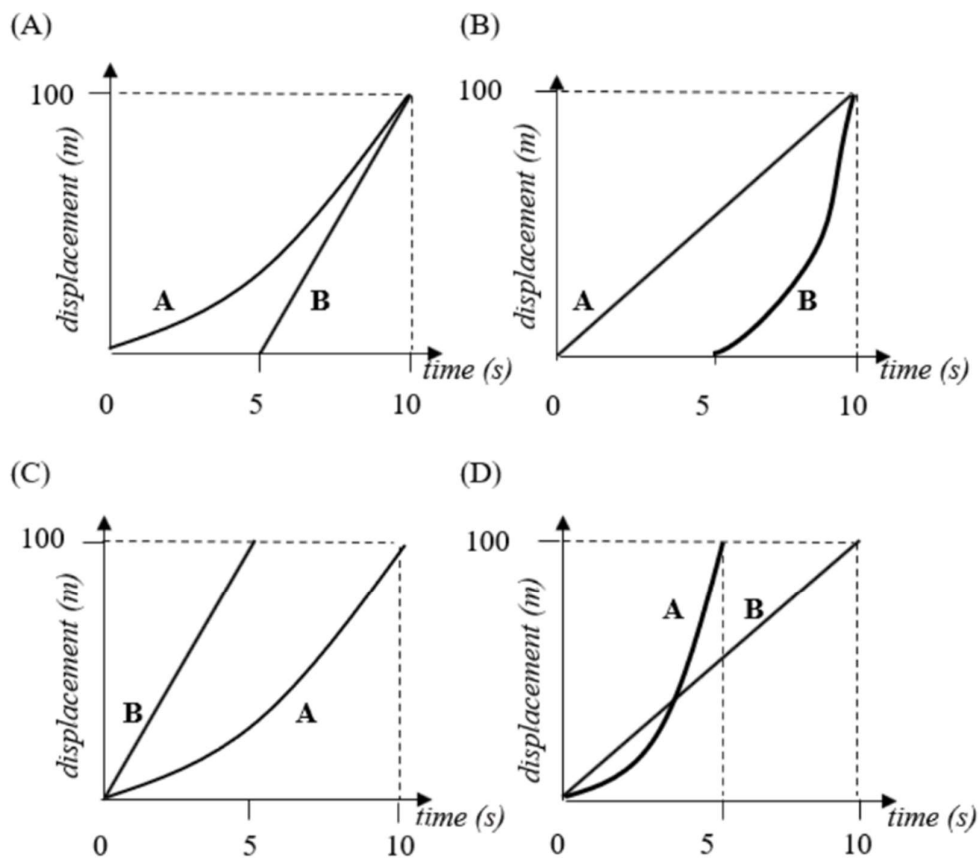

19. A wave is passing through a rope fixed to a bolt on the wall as shown below.

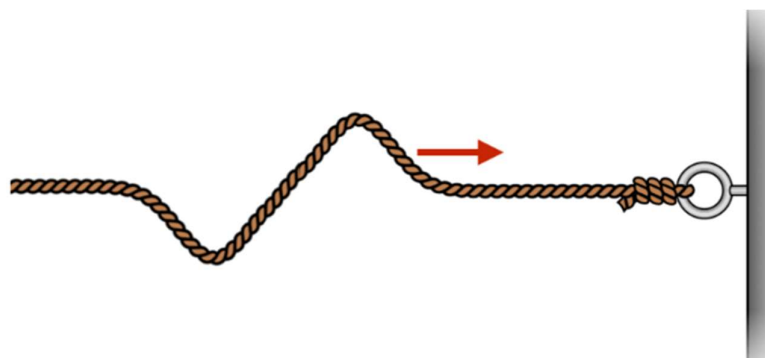

How will the wave reflect from the wall?

- A. With a  $180^\circ$  phase change, meaning crests reflect as troughs and troughs reflect as crests.
- B. With no phase change, meaning crests reflect as crests and troughs reflect as troughs.
- C. With a  $90^\circ$  phase change, meaning crests reflect as troughs and troughs reflect as crests.

D. With a  $360^\circ$  phase change, meaning crests reflect as crests and troughs reflect as troughs.

20. A yellow motorbike and a red motorbike are approaching the same intersection at different velocities.

The yellow motorbike is travelling at a velocity of  $16 \text{ m s}^{-1}$  heading north. The red motorbike is travelling at a velocity of  $19 \text{ m s}^{-1}$  heading east.

What is the velocity of the yellow motorbike relative to the red motorbike?

- A.  $35 \text{ m s}^{-1}$  N40°E
- B.  $25 \text{ m s}^{-1}$  N50°E
- C.  $35 \text{ m s}^{-1}$  N40°W
- D.  $25 \text{ m s}^{-1}$  N50°W

**End of Section I**

**Question 21** (3 marks)

A 1.2 kg mass slides along a rough horizontal surface and comes to rest after 15 s. The graph shows the journey of the mass.

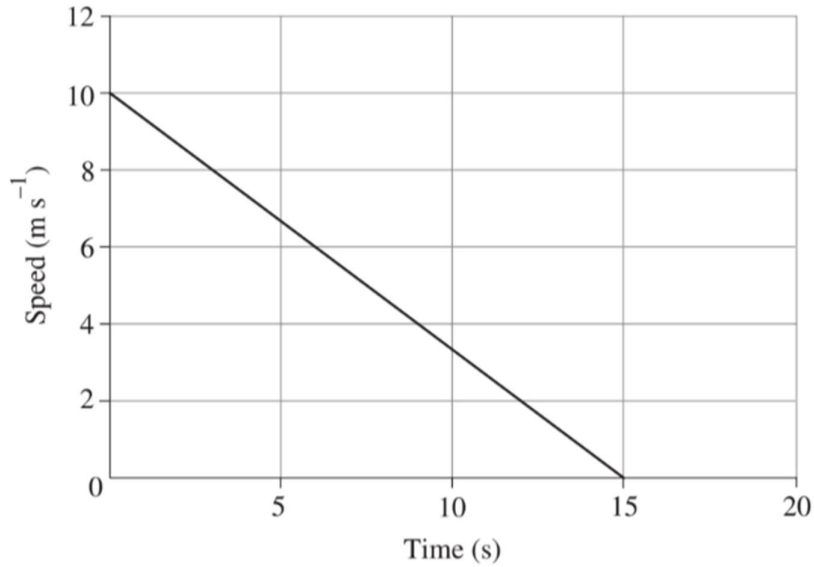

Calculate the magnitude of friction force acting on the mass.

3

.....

.....

.....

.....

**Question 22** (3 marks)

A 65.0 g arrow is shot directly upwards into the air from the top of a 65.0 m pole at a speed of 48.0 m s<sup>-1</sup>.

Calculate the kinetic energy of the arrow when it reaches the ground. Show all working out.

3

.....

.....

.....

.....

.....

.....

.....



**Question 24** (4 marks)

In a game of tug of war, teams  $\alpha$ ,  $\beta$  and  $\gamma$  each pull their rope away from the knot in the centre with a horizontal force of 2500 N south, 2700 N north-east and 1800 N north-west, respectively.

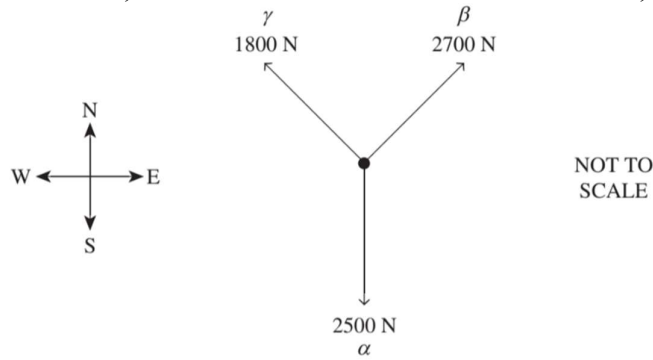

Calculate the magnitude and direction of the net horizontal force acting on the knot.

4

.....

.....

.....

.....

.....

.....

.....

**Question 25** (3 marks)

A skateboarder is riding south. They slow from a speed of  $6.0 \text{ m s}^{-1}$  to  $4.0 \text{ m s}^{-1}$  over 1.9 s when turning a corner to travel west.

Calculate the magnitude and direction of the skateboarder's average acceleration and draw a vector diagram to support your answer.

3

.....

.....

.....

.....

.....

.....

.....



**Question 27** (4 marks)

The Bédoin to Mont Ventoux bicycle route in France is one of the most difficult bicycle routes in the world. Bédoin has an elevation of 283 m above sea level and the top of Mont Ventoux has an elevation of 1912 m above sea level.

The combined mass of a cyclist and their bicycle is 86.0 kg. They start riding at Bédoin and end at the top of Mont Ventoux.

- a) What is the cyclist's gain in gravitational potential energy? **2**

.....

.....

.....

.....

.....

.....

- b) After reaching the end of the route, the cyclist turns around and begins to return from the top of Mont Ventoux. From a stationary start, the cyclist freewheels down the mountain (they do not pedal or brake). A spectator is located on the route at an elevation of 1876 m above sea level. **2**

What is the cyclist's speed when they pass the spectator? Ignore friction and any other resistive forces.

.....

.....

.....

.....

.....

.....







**Question 31** (5 marks)

In the electrical circuit below, the reading on the voltmeter is 6 V.

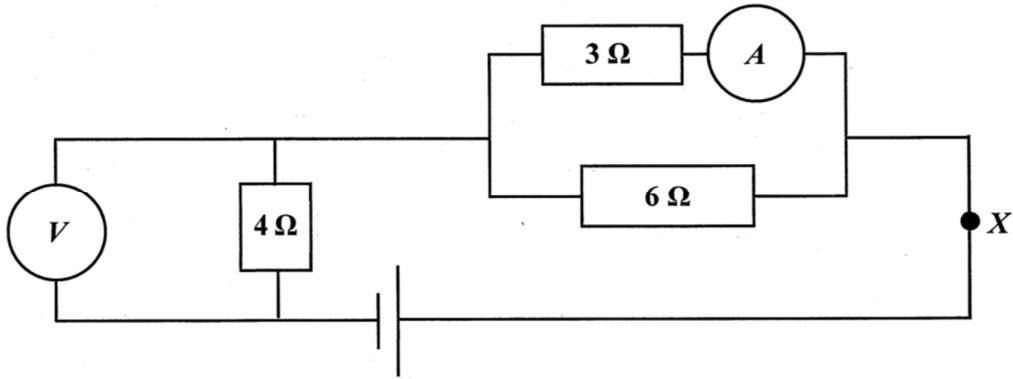

- a) What is the total resistance of this circuit? 1

.....

.....

- b) What voltage is supplied by the battery? 1

.....

.....

- c) What is the reading on the ammeter? 1

.....

.....

- d) On the diagrams an arrow to clearly label the current direction at point X. 1

- e) Compare the relative resistance of ammeters and voltmeters. 1

.....

.....

.....

.....

**Question 32** (3 marks)

The total mass of a freight train is  $4.5 \times 10^6$  kg. A section of straight track has a grade of 1:110 (i.e., it rises a vertical distance of 1 m from every 110 m horizontal).

Calculate the power the locomotive needs to supply to haul this train up the slope at  $5.0 \text{ m s}^{-1}$ .

**3**

.....

.....

.....

.....

.....

.....

.....

**Question 33** (3 marks)

Two long straight parallel wires are separated by a distance of 55 cm and carry equal magnitude currents in opposite directions.

The magnitude of the magnetic field halfway between the wire is  $130 \mu\text{T}$ .

Calculate the magnitude of the current in each wire.

**3**

.....

.....

.....

.....

.....

.....

.....

## Section I

20 marks

Attempt Questions 1–20

Allow about 35 minutes for this section

Use the multiple-choice answer sheet for Questions 1–20.

---

1. A concave lens is shown.

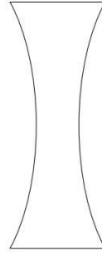

Which of the following statements about concave lenses is true?

- A. **They can only form virtual images.**
- B. They can only form enlarged, inverted images.
- C. They can only reflect incident light rays, not refract them.
- D. They can form both virtual and real images, depending on the location of the object.

A is correct and D is incorrect. Concave (diverging) lenses can only form virtual images because they cannot bring light rays to focus at a point.

2.  $1 \text{ kWh}^{-1}$  is equivalent to 3.6 MJ.

How much energy would be used if a  $2000 \text{ Wh}^{-1}$  hairdryer were left switched on for 2.5 hours?

- A. 7.2 MJ
- B. 9.0 MJ
- C. **18 MJ**
- D. 36 MJ

$$2000 \text{ W} = 2 \text{ kW}$$

$$2 \text{ kW} \times 2.5 \text{ hours} = 5 \text{ kWh}$$

$$\text{Given that } 1 \text{ kWh} = 3.6 \text{ MJ}, 5 \text{ kWh} \times 3.6 = 18 \text{ MJ}.$$

3. A 2.0 kg ball is held at rest in the air above a flat surface, giving the ball 14.7 J of gravitational potential energy.

How far above the flat surface is the ball being held?

- A. 7.5 m
- B. 29 m
- C. **75 cm**
- D. 90 cm

$$\begin{aligned} \Delta h &= \frac{\Delta U}{mg} \\ &= \frac{14.7}{2.0 \times 9.8} \\ &= 0.75 \text{ m} \\ &= 75 \text{ cm} \end{aligned}$$

4. The first harmonic for a pipe that is closed at one end, such as a didgeridoo, will have one pressure node (N) and one pressure antinode (A), as shown in the diagram.

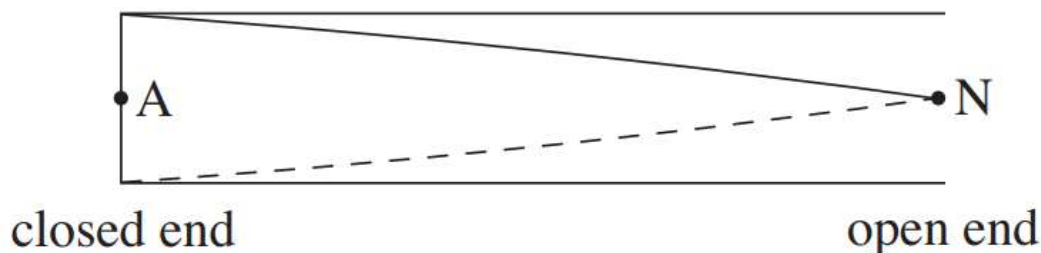

How many pressure nodes must there be for the third harmonic?

- A. 1  
 B. 2  
 C. 3  
 D. 4

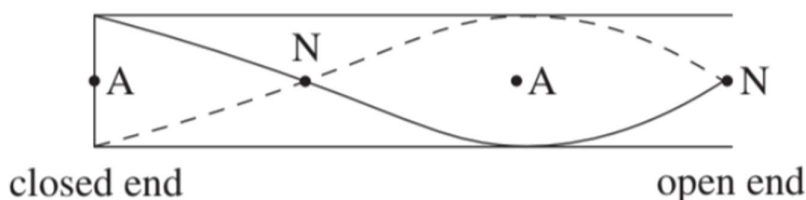

Pipes that are closed at one end must have a pressure antinode at the closed end and a pressure node at the open end. Given that the wavelength of the first harmonic is four times the length of the pipe, a second harmonic cannot form; it would be twice the length of the pipe, which would result in a pressure antinode at the open end. The third harmonic has a wavelength that is  $4/3$  times longer than the length of the pipe, resulting in two pressure nodes as shown in the following diagram.

5. In a Hydrogen atom, there is a single proton with a single electron orbiting. If the radius of an electron's orbit around a proton is  $5.3 \times 10^{-11}$  m, what is the strength of the electric field acting on the electron during its orbit?

- A.  $27 \text{ N C}^{-1}$   
 B.  $54 \text{ N C}^{-1}$   
 C.  $5.1 \times 10^{11} \text{ N C}^{-1}$   
 D.  $1.0 \times 10^{12} \text{ N C}^{-1}$

$$E = \frac{F}{q}$$

$$F = \frac{1}{4\pi\epsilon_0} \frac{q_1 q_2}{r^2}$$

Therefore:

$$E = \frac{1}{4\pi\epsilon_0} \frac{q}{r^2}$$

$$= \frac{1}{4\pi \times 8.854 \times 10^{-12}} \times \frac{1.602 \times 10^{-19}}{(5.3 \times 10^{-11})^2}$$

$$= 5.1 \times 10^{11} \text{ N C}^{-1}$$

6. Consider the electric circuit shown. Each resistor has the same amount of resistance.

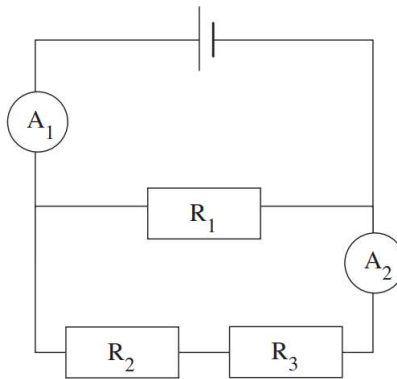

If the circuit operates with a constant voltage supply, which of the following statements is correct?

- A. Ammeter  $A_2$  measures a higher current than ammeter  $A_1$ .
- B. **Resistor  $R_1$  has a higher voltage drop than resistors  $R_2$  or  $R_3$ .**
- C. Resistors  $R_2$  and  $R_3$  have a higher combined voltage drop than resistor  $R_1$ .
- D. The total resistance in the circuit would increase by a third if resistor  $R_3$  was removed.

**B** is correct. Resistors  $R_2$  and  $R_3$  are in series and therefore have half the voltage drop each compared to resistor  $R_1$ .

**A** is incorrect. Ammeter  $A_1$  will measure a higher current than ammeter  $A_2$  as it is measuring the total current in the circuit, not just one of the branches.

**C** is incorrect. The combined voltage drop of resistors  $R_2$  and  $R_3$  is equivalent to the voltage drop of resistor  $R_1$ .

**D** is incorrect. The total resistance in the circuit would decrease if resistor  $R_3$  was removed.

7. A box is accelerating down an inclined plane.

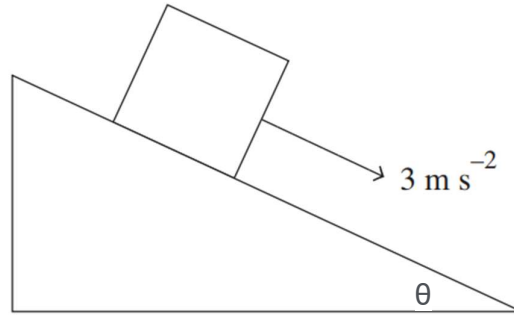

The magnitude of the friction force is half the magnitude of the normal force acting on the box. If the angle  $\theta$  is known, the magnitude of the net force acting on the box can be determined completely by

- A. calculating half the magnitude of the normal force.
- B. calculating the component of the box's weight acting down the inclined plane.
- C. **calculating the component of the box's weight acting down the inclined plane, then subtracting half the magnitude of the normal force.**
- D. subtracting the magnitude of the box's weight from the magnitude of the normal force.

If the box is accelerating down the inclined plane, the net force on the box must be acting down the inclined plane. Therefore, the magnitude of the net force acting on the box can be determined by calculating the component of the box's weight acting down the inclined plane, then subtracting the magnitude of the friction force, which is equivalent to half the magnitude of the normal force. This is shown in the following diagram

8. A and B are two charged spheres. Initially, the spheres are at a distance of  $r$  metres apart. Each sphere has a charge of  $q$  coulombs. There is a repulsive force of  $F$  newtons between them. The distance between the two spheres is then increased to  $2r$ . The charge on sphere A changes to  $0.6q$  coulombs, and the charge on sphere B remains the same.

What is the new magnitude of the repulsive force between the spheres?

- A.  $0.09F$  Newtons
  - B.  **$0.15F$  Newtons**
  - C.  $0.30F$  Newtons
  - D.  $1.00F$  Newtons
- $F \propto \frac{q_1 q_2}{r^2}$   
 $F = \frac{0.6 \times 1}{2^2}$   
 $= 0.15$   
 Therefore, the new magnitude of the repulsive force is  $0.15F$  newtons.

9. A surfer times the period of the waves arriving at the beach at 7.5 s and estimates the wavelength to be 55 m.

The velocity of the waves is nearest to

- A.  $0.136 \text{ m s}^{-1}$
- B.  $41.3 \text{ m s}^{-1}$
- C.  $13.6 \text{ m s}^{-1}$
- D.  **$7.33 \text{ m s}^{-1}$**

$$f = \frac{1}{T} = \frac{1}{7.5} = 0.1333 \text{ Hz}$$

**Answer:** *velocity = frequency  $\times$  wavelength*

$$v = f \lambda = 0.1333 \times 55 = 7.33 \text{ m.s}^{-1}$$

10. Two positive charges of magnitude  $Q$  and  $2Q$  are equidistant from point  $P$ .

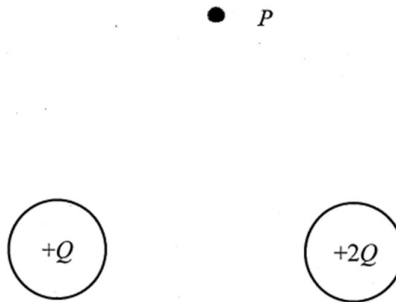

Which vector best represents the direction of the electric field at point  $P$ ?

- A.
- B.
- C.
- D.

Answer is A

Both charges are positive, so field lines would extend out from the charges.

As  $+2Q$  would have a greater effect than  $+Q$ , therefore slightly to the right.

11. The refractive index of a transparent plastic is 1.98 and the refractive index of a liquid is 1.12. The critical angle for total internal reflection of light in the plastic when it is immersed in the liquid is nearest to

- A.  $0.57^\circ$
- B.  **$34^\circ$**
- C.  $1.77^\circ$
- D.  $0.99^\circ$

Critical angle is given by  $\sin(\theta) = n_2/n_1$ .

Light going from region 1 to region 2 so for light in the plastic  $n_1 = 1.98$  and for light in the liquid  $n_2 = 1.12$ .

$$1.12/1.98 = 0.5657$$

$$\sin^{-1}(0.5657) = 34.448$$

12. A dust particle with 22 excess electrons is subjected to an electric force of  $2.56 \times 10^{-13}$  N when it is between two parallel metal plates separated by 8.0 mm. The voltage applied to the plates will be nearest to.

- A. 73 V
- B. 704 V
- C. **582 V**
- D. 2.8 V

Answer : This is a two step problem. First calculate the strength of the electric field and then use this value to determine the voltage applied to the plates.

$$\text{Given } q = 22e = 22 \times 1.60 \times 10^{-19} = 3.520 \times 10^{-18} \text{ C}$$

$$F = qE, \therefore E = \frac{F}{q} = \frac{2.56 \times 10^{-13}}{3.520 \times 10^{-18}} = 7.273 \times 10^4 \text{ V.m}^{-1}$$

Now for parallel plated with a separation of  $d = 0.0080$  m

$$E = \frac{V}{d}, \therefore V = Ed = 7.273 \times 10^4 \times 0.0080 = 582 \text{ V}$$

13. A satellite of mass 1850 kg has a manoeuvring rocket motor which can provide 30 N of thrust. If the rocket motor is fired for 17 s, the change in velocity of the satellite will be nearest to

- A. **0.28 m s<sup>-1</sup>**
- B. 0.55 m s<sup>-1</sup>
- C. 2.34 m s<sup>-1</sup>
- D. 3.63 m s<sup>-1</sup>

Answer: impulse = change in momentum

$$Ft = m\Delta v$$

$$\Delta v = \frac{Ft}{m} = \frac{30 \times 17}{1850} = 0.28 \text{ m.s}^{-1}$$

14. A photo of a small section of the night sky showing two very bright stars (A and B). Measurements of the spectra of the two stars show that they are actually of equal size, temperature and brightness.

In the photo, Star A appears to be 4 times brighter than Star B.

If the distance to Star A is known to be 4.5 light years, the approximate distance to Star B in light years is

- A) **9.0**
- B) 18.0
- C) 20.25
- D) 81.0

Inverse Square laws states that the brightness (luminosity) of a source decreases with the square of the distance.

$$\text{Lum}_A / \text{Lum}_B = d_B^2 / d_A^2$$

Solve for  $d_B$

$$d_B^2 = 4 \times 4.5^2$$

$$d_B^2 = 81 \text{ so } d_B = \sqrt{81} = 9 \text{ light years}$$

15. The diagram shows a simple experiment done by a student in a physics class.

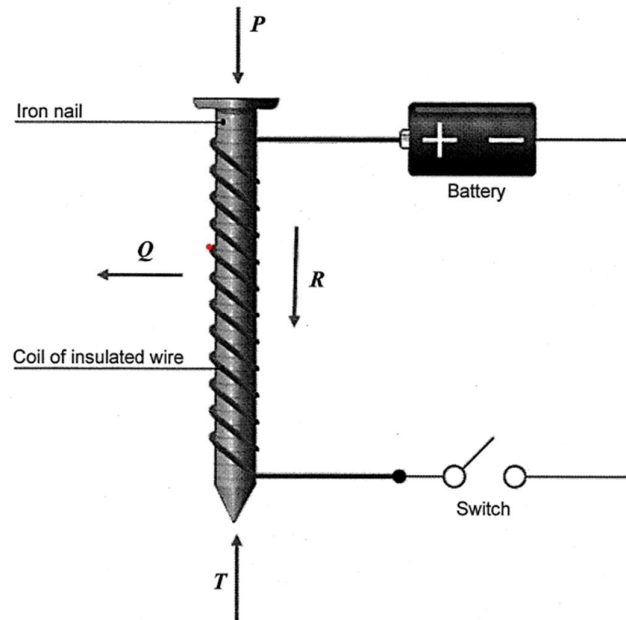

Which of the arrows correctly indicates the direction of the magnetic field at their locations when the switch is closed?

- A. *P* only
- B. *T* only
- C. *P* and *Q*
- D. ***T* and *R***

Right Hand Grip Rule

16. Conservation laws underpin Kirchhoff's current and voltage laws.

If Kirchhoff's current law was not applicable, it would mean that:

- A. there would be higher voltages measured around a circuit than the supplied EMF.
- B. **the creation or destruction of electrons would occur.**
- C. electrons would flow around the circuit in one direction only.
- D. the electric circuit would have higher resistance.

Either do not apply to the situation described or are not applicable. B is the only effect if Kirchhoff's current didn't apply then at junctions on a circuit electrons would be created or destroyed.

17. How much energy would need to be transferred to 140 L of water to raise its temperature from 20°C to 65°C?

- A.  $2.6 \times 10^4$  J
- B.  $1.9 \times 10^5$  J
- C.  $1.2 \times 10^7$  J
- D.  **$2.6 \times 10^7$  J**

$$Q = mc\Delta T$$

specific heat capacity of water,  $c = 4.18 \times 10^3 \text{ J kg}^{-1} \text{ K}^{-1}$

density of water,  $\rho = 1.00 \times 10^3 \text{ kg m}^{-3}$

$$140 \text{ L} = 140 \text{ kg}$$

$$\begin{aligned} \Delta T &= 65 - 20 \\ &= 45^\circ\text{C} \end{aligned}$$

$$\begin{aligned} Q &= 140 \times (4.18 \times 10^3) \times 45 \\ &= 2.6 \times 10^7 \text{ J} \end{aligned}$$

18. Two toy cars have a race over a 100 m straight track. Car A starts from rest with a constant acceleration of  $2.0 \text{ m s}^{-2}$ . Car B starts 5.0 s after car A but has a constant speed of  $20 \text{ m s}^{-1}$ .

Select the graph that correctly depicts the motion of the two cars.

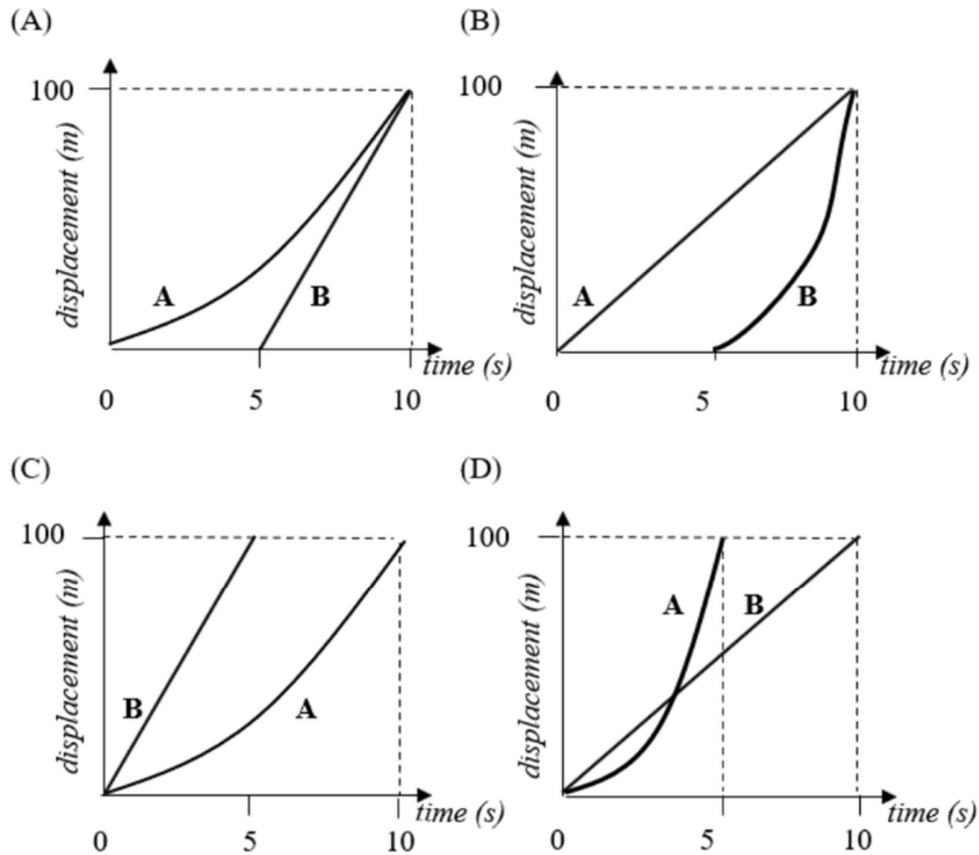

A is correct.

19. A wave is passing through a rope fixed to a bolt on the wall as shown below.

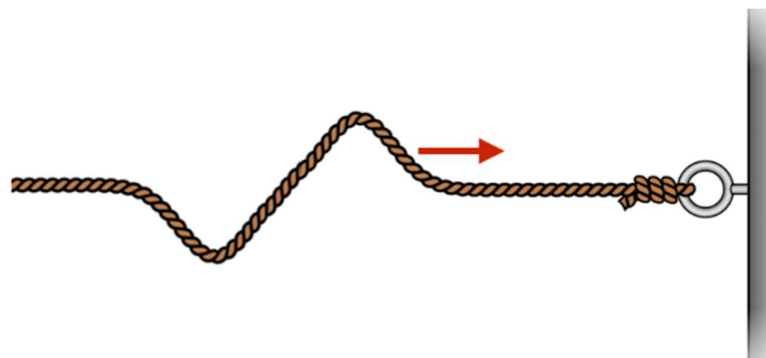

How will the wave reflect from the wall?

- A. **With a  $180^\circ$  phase change, meaning crests reflect as troughs and troughs reflect as crests.**
- B. With no phase change, meaning crests reflect as crests and troughs reflect as troughs.
- C. With a  $90^\circ$  phase change, meaning crests reflect as troughs and troughs reflect as crests.
- D. With a  $360^\circ$  phase change, meaning crests reflect as crests and troughs reflect as troughs.

20. A yellow motorbike and a red motorbike are approaching the same intersection at different velocities.

The yellow motorbike is travelling at a velocity of  $16 \text{ m s}^{-1}$  heading north. The red motorbike is travelling at a velocity of  $19 \text{ m s}^{-1}$  heading east.

What is the velocity of the yellow motorbike relative to the red motorbike?

- A.  $35 \text{ m s}^{-1}$  N40°E
- B.  $25 \text{ m s}^{-1}$  N50°E
- C.  $35 \text{ m s}^{-1}$  N40°W
- D.  **$25 \text{ m s}^{-1}$  N50°W**

**D** is correct, and **A** and **C** are incorrect.

$$v_{YR} = v_Y + (-v_R)$$

$$-v_R = 19 \text{ m s}^{-1}$$

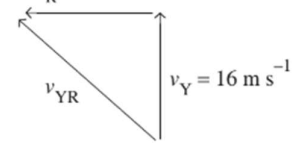

$$v_{YR} = \sqrt{19^2 + 16^2}$$

$$= 25 \text{ m s}^{-1}$$

$$\tan \theta = \frac{19}{16}$$

$$\theta = \tan^{-1}\left(\frac{19}{16}\right)$$

$$= 50^\circ$$

**End of Section I**

$$v_{YR} = 25 \text{ m s}^{-1} \text{ N}50^\circ\text{W}$$

**B** is incorrect. The red motorbike is heading east. Therefore, the yellow motorbike is heading west relative to the red motorbike.

**Question 21** (3 marks)

A 1.2 kg mass slides along a rough horizontal surface and comes to rest after 15 s. The graph shows the journey of the mass.

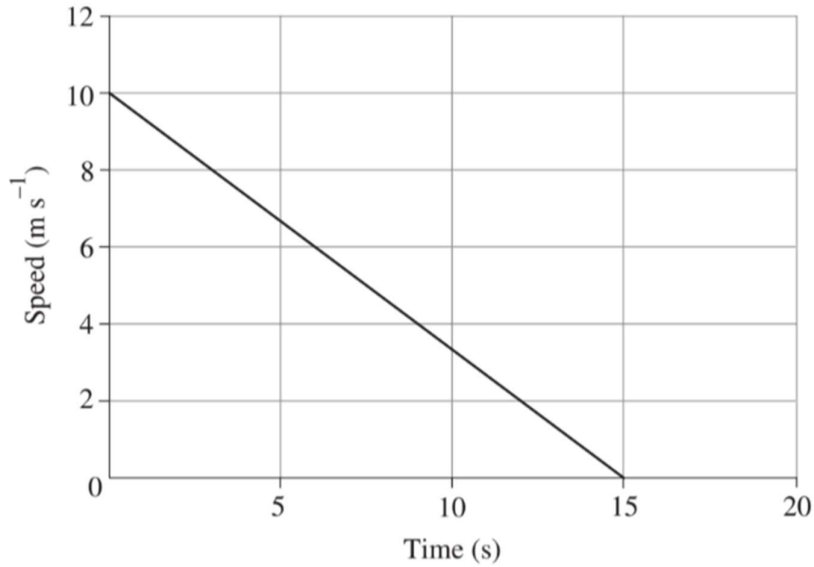

Calculate the magnitude of friction force acting on the mass.

$$\begin{aligned}
 a &= \frac{v - u}{t} && \dots\dots\dots 3 \\
 &= \frac{0 - 10}{15} && \dots\dots\dots \\
 &= -0.6667 \text{ m s}^{-2} && \dots\dots\dots \\
 \vec{F}_{\text{net}} &= m\vec{a} && \dots\dots\dots \\
 &= 1.2 \times 0.6667 && \dots\dots\dots \\
 &= 0.80 \text{ N} && \dots\dots\dots
 \end{aligned}$$

Marks	Criteria
3	Student is able to calculate the magnitude of the friction force as 0.80 N.
2	Student is able to calculate the acceleration of the mass as -0.6667 m s <sup>-2</sup> but unable to calculate the force.
1	Students shows some relevant working out, but values are incorrect.
0	Student is shows no understanding on how to calculate either acceleration or force.

**Question 22** (3 marks)

A 65.0 g arrow is shot directly upwards into the air from the top of a 65.0 m pole at a speed of  $48.0 \text{ m s}^{-1}$ .

Calculate the kinetic energy of the arrow when it reaches the ground. Show all working out.

3

or calculate total displacement and then use the kinetic energy to calculate the v

$$\begin{aligned}v^2 &= u^2 + 2as \\v^2 &= 48.0^2 + 2 \times -9.8 \times 65.0 \\v^2 &= 3578 \\v &= \sqrt{3578} \\&= 59.8164 \text{ m s}^{-1} \text{ down} \\K &= \frac{1}{2}mv^2 \\&= \frac{1}{2} \times 0.065 \times 59.8164^2 \\&= 116 \text{ J}\end{aligned}$$

Mark	Criteria
3	Calculates the kinetic energy of the arrow as 116 J when it reaches the ground AND shows all working out.
2	Calculates the velocity of the arrow as $59.8164 \text{ m s}^{-1}$ down but cannot calculate the kinetic energy
1	Shows some relevant working out

**Question 23** (5 marks)

A student set up a simple electric circuit to determine the relationship between current and voltage in ohmic resistors. They began with the circuit shown in the diagram with a  $2 \Omega$  resistor, and had access to a voltmeter, ammeter, a  $4 \Omega$  resistor and a  $6 \Omega$  resistor.

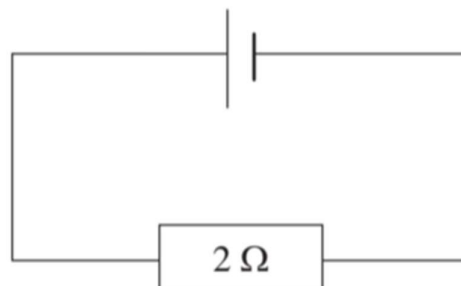

Describe how the student could investigate the relationship between current and voltage in ohmic resistors with this equipment. Justify your choices.

The student should place the ammeter in series with the circuit to measure the current flowing through the circuit .....  
and therefore through the resistor.

They should place the voltmeter in parallel with the resistor .....  
to measure the voltage drop across the resistor.

After switching on the power supply at a set voltage, .....  
the student should measure and record the voltage and .....  
current through the 2 Ω resistor. The student should then .....  
vary the voltage provided by the power supply, measuring .....  
and recording the voltage and current through the resistor .....  
each time the power supply is changed. The temperature .....  
of the wires would need to be kept constant, which may .....  
be achieved by switching off the power supply between .....  
each measurement. The student should then repeat these .....  
steps using the 4 Ω and 6 Ω resistors and plot their .....  
results in a voltage versus current graph. The relationship .....  
between current and voltage in ohmic resistors can then .....  
be determined by analysing the trendlines for each resistor.

Mark	Criteria
5	Describes how current should be measured AND Describes how voltage should be measured AND Describes how 2 Ω, 4 Ω and 6 Ω resistors should be used AND Identifies how the relationship between current and voltage in ohmic resistors will be determined AND Identifies that for Ohmic resistors the trendlines obtained should be linear AND Identifies a relevant controlled variable
4	Any FIVE of the above points
3	Any FOUR of the above points
2	Any THREE of the above points
1	Any ONE of the above points

**Question 24** (4 marks)

In a game of tug of war, teams  $\alpha$ ,  $\beta$  and  $\gamma$  each pull their rope away from the knot in the centre with a horizontal force of 2500 N south, 2700 N north-east and 1800 N north-west, respectively.

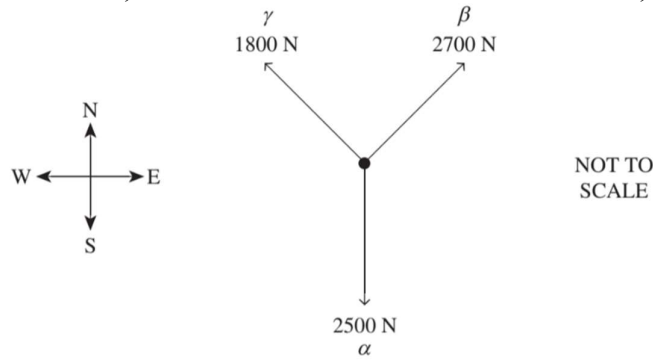

Calculate the magnitude and direction of the net horizontal force acting on the knot.

4

.....or 933N E47°N

.....

.....

.....

$$F_x = F_{x\alpha} + F_{x\beta} + F_{x\gamma}$$

$$= 0 + 2700\cos(45) - 1800\cos(45)$$

$$= 636.3961 \text{ N}$$

$$F_y = F_{y\alpha} + F_{y\beta} + F_{y\gamma}$$

$$= -2500 + 2700\sin(45) + 1800\sin(45)$$

$$= 681.9805 \text{ N}$$

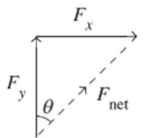

$$F_{\text{net}} = \sqrt{F_x^2 + F_y^2}$$

$$= \sqrt{636.3961^2 + 681.9805^2}$$

$$= 933 \text{ N}$$

$$\theta = \tan^{-1}\left(\frac{F_x}{F_y}\right)$$

$$= \tan^{-1}\left(\frac{636.3961}{681.9805}\right)$$

$$= 43^\circ$$

Therefore, the net horizontal force acting on the knot is 933 N N43°E.

4	Calculates the magnitude AND direction of the net horizontal force acting on the knot
3	Calculates the magnitude of the net horizontal force acting on the knot.
2	Makes some progress towards calculating the magnitude of the net horizontal force acting on the knot
1	Provides some relevant working

**Question 25** (3 marks)

A skateboarder is riding south. They slow from a speed of  $6.0 \text{ m s}^{-1}$  to  $4.0 \text{ m s}^{-1}$  over  $1.9 \text{ s}$  when turning a corner to travel west.

Calculate the magnitude and direction of the skateboarder's average acceleration and draw a vector diagram to support your answer.

3

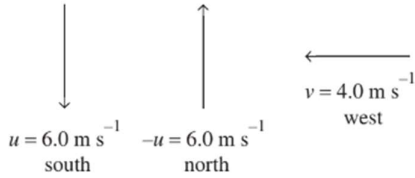

.....or  $3.8 \text{ m/s}^2 \text{ W}56^\circ\text{N}$

.....

.....

.....

.....

.....

.....

.....

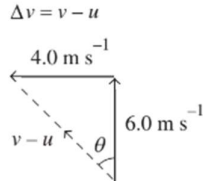

Using Pythagoras' theorem gives:

$$(v - u)^2 = 4.0^2 + 6.0^2$$

$$v - u = 7.2111 \text{ m s}^{-1}$$

Using trigonometry gives:

$$\theta = \tan^{-1}\left(\frac{4.0}{6.0}\right)$$

$$= 34^\circ$$

$$a = \frac{v - u}{t}$$

$$= \frac{7.2111}{1.9}$$

$$= 3.8$$

Therefore, the average acceleration is  $3.8 \text{ m s}^{-2} \text{ N}34^\circ\text{W}$ .

Mark	Criteria
3	Calculates the magnitude AND direction of the average acceleration AND Draws a vector diagram to support the answer
2	Completes 2 of the above criteria but missing one
1	Makes some progress toward calculating the average acceleration OR Draws an appropriate vector diagram

**Question 26** (4 marks)

Water has a refractive index of 1.33. A person standing on the edge of a swimming pool at night shines a narrow beam of light from a torch onto the surface of the pool as illustrated.

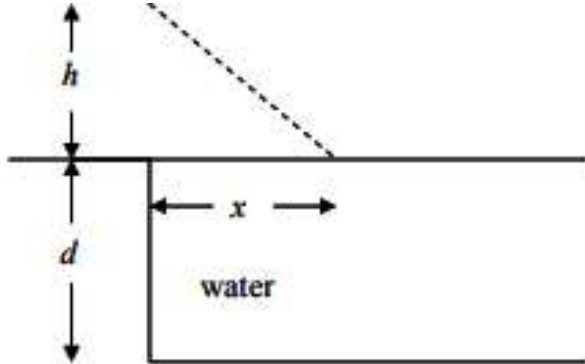

The torch is 1.20 m above the edge of the pool and the light beam strikes the surface of the 2.20 m from the edge of the pool

If the pool has a flat bottom and is 1.80 m deep, calculate the distance from the edge of the pool at which the light beam will strike the bottom of the pool. Show all working.

4

Answer: Sketch the situation as shown below

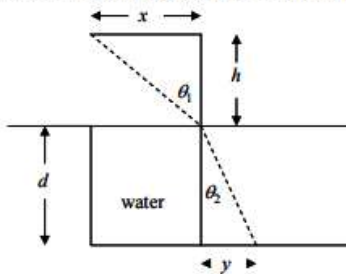

This is a multi step problem

First, calculate  $\theta_1$ . Hint  $\tan \theta_1 = \frac{x}{h}$

Second, use the law of refraction to find  $\theta_2$

Third, use simple geometry to calculate the distance  $y$

Finally the total distance from the edge is just  $x + y$  (Ans 3.78 m)

$$\tan \theta_1 = \frac{x}{h}$$

$$\tan \theta_1 = \frac{2.20}{1.20}, \theta_1 = 61.3^\circ$$

$$\frac{\sin \theta_1}{\sin \theta_2} = \frac{n_2}{n_1}$$

$$\sin \theta_2 = \frac{\sin 61.3^\circ}{1.33}$$

$$\theta_2 = 41.3^\circ$$

$$\tan \theta = \frac{y}{d}, y = \tan \theta \times d$$

$$y = \tan 41.3^\circ \times 1.8 = 1.58\text{m}$$

$$X + y = 1.58 + 2.2 = 3.78\text{m}$$

Mark	Criteria
4	Calculates the total distance from the edge of the pool AND shows all working out.
3	Calculates the total distance from the edge of the pool with ONE omission or error in working out
2	Calculates the angle of refraction (theta 2)
1	Shows some relevant working out

**Question 27** (4 marks)

The Bédoin to Mont Ventoux bicycle route in France is one of the most difficult bicycle routes in the world. Bédoin has an elevation of 283 m above sea level and the top of Mont Ventoux has an elevation of 1912 m above sea level.

The combined mass of a cyclist and their bicycle is 86.0 kg. They start riding at Bédoin and end at the top of Mont Ventoux.

a) What is the cyclist’s gain in gravitational potential energy? 2

(a)  $\Delta U = mg\Delta h$  .....  
 $= 86.0 \times 9.8 \times (1912 - 283)$  .....  
 $= 1.37 \times 10^6 \text{ J}$  .....

Mark	Criteria
2	Calculates the gain in GPE AND includes correct significant figures. (3 sig figs)
1	Calculates the gain in GPE

b) After reaching the end of the route, the cyclist turns around and begins to return from the top of Mont Ventoux. From a stationary start, the cyclist freewheels down the mountain (they do not pedal or brake). A spectator is located on the route at an elevation of 1876 m above sea level. What is the cyclist’s speed when they pass the spectator? Ignore friction and any other resistive forces. 2

(b) difference in height between the top of Mont Ventoux and the spectator’s location  
 $= 1912 - 1876$   
 $= 36 \text{ m}$  .....

**Method 1:**

$mg\Delta h = \frac{1}{2}mv^2$  .....  
 $2 \times 9.8 \times 36 = v^2$  .....  
 $v = \sqrt{705.6}$  .....  
 $= 26.6 \text{ m s}^{-1}$  .....

**Method 2:**

Using kinematic equations gives: .....  
 $v^2 = u^2 + 2as$  .....  
 $v = \sqrt{2as}$  .....  
 $= \sqrt{2 \times 9.8 \times 36}$  .....  
 $= 26.6 \text{ m s}^{-1}$  .....

Mark	Criteria
2	Calculates the cyclist’s speed when they pass the spectator
1	Provides some relevant working

**Question 28** (6 marks)

Using examples, explain how each of Newton’s Laws of Motion can be observed in everyday situations.

6

**Sample Answers**

Newton’s 1<sup>st</sup> Law of Motion – the law of inertia: when a bus stops suddenly, standing passengers are flung forward (relative to the bus) but in fact are retaining their state of motion until acted upon by an unbalanced force – e.g. hitting the front of the bus.

Newton’s 2<sup>nd</sup> Law of Motion –  $F = ma$  : the unbalanced force acting on an object is equal to the object’s mass multiplied by its acceleration. Pushing a toy car with twice the force will result in the doubling of its acceleration.

Newton’s 3<sup>rd</sup> Law of Motion – for every action there is an equal and opposite reaction: when a cannon is fired, the projectile is fired forwards but the cannon itself recoils with equal but opposite (direction) momentum.

Marking Criteria	Marks
<ul style="list-style-type: none"> <li>Each law is correctly identified and described clearly in a concise manner.</li> <li>Relevant examples used for each law</li> <li>Response is clear, concise and organised</li> </ul>	6
<ul style="list-style-type: none"> <li>For incorrect or insufficient identifications of Newtons Laws</li> </ul>	-1
<ul style="list-style-type: none"> <li>Student gives an example that is vague, irrelevant, or incorrect.</li> </ul>	-1

**Question 29** (7 marks)

Three friends, Paul, Tom and Nick are spending their afternoon swimming in the local river that flows to the East at  $0.44 \text{ m s}^{-1}$ .

Nick is travelling  $1.50 \text{ m s}^{-1}$   $S17^\circ E$  relative to Tom.

Paul is swimming  $1.50 \text{ m s}^{-1}$   $N45^\circ W$  relative to Nick.

a) What velocity is Tom swimming relative to Paul?

4

$v_{PT} = v_{PN} + v_{NT}$  .....

$v_{PT_x} = v_{PN_x} + v_{NT_x}$  .....

$v_{PT_x} = 1.5 \cos 73 - 1.5 \cos 45$  .....

$v_{PT_x} = -0.62$  .....

$v_{PT_y} = v_{PN_y} + v_{NT_y}$  .....

$v_{PT_y} = -1.5 \sin 73 + 1.5 \sin 45$  .....

$v_{PT_y} = -0.37$  .....

.....

.....

.....

.....

.....

Mark	Criteria
4	Correctly calculates Velocity of Tom relative to Paul
3	Correctly calculates the magnitude of the Velocity of Tom relative to Paul
2	Shows relevant working with incorrect substitution
1	Attempts to use relative velocity formula

- b) If Tom is swimming to the north bank directly opposite from where he left the south bank and Nick is maintaining his distance from the North bank. How fast is Nick swimming relative to the water? **3**

$v_{NT} = v_N - v_T$  .....

$v_N = v_{NT} + v_T$  .....

$v_N = v_{NT_x} + v_{T_x}$  .....

$v_N = 1.5 \cos 73 + 0$  .....

$v_N = 0.44 \text{ m s}^{-1}$  i.e. the same as the river .....

$\therefore v_{NW} = 0$  .....

.....

.....

.....

Mark	Criteria
3	Determines correctly the velocity of Nick relative to the water
2	Calculates the velocity of Nick
1	Attempts to find Nicks velocity

**Question 30 (5 marks)**

A woman stands somewhere between two cliffs that are separated by 1410 m. She makes a loud noise and measures the time it takes to hear the echoes. She hears two distinct echoes separated by 1.5 s.

She then walks 133 m towards the closest cliff and repeats the process.

The first echo is heard after 2.7 s.

a) Calculate the velocity of sound in the air.

3

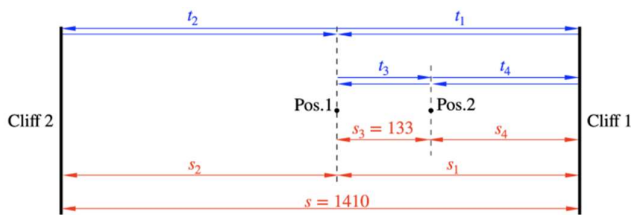

.....

.....

$$t_1 = t_3 + t_4$$

$$t_3 = \frac{2s_3}{v}$$

$$t_4 = 2.7 \text{ s}$$

$$t_2 = t_1 + 1.5$$

$$t_3 = \frac{2 \times 133}{v}$$

.....

.....

.....

.....

.....

.....

.....

.....

Mark	Criteria
3	Correctly calculates the speed of sound using the given values
2	Shows significant progress using expressions for displacements and times to solve for speed
1	Shows some relevant working

b) If the speed of sound in air was  $340 \text{ m s}^{-1}$ , determine her initial distance from the furthest cliff. **2**

$$s = s_1 + s_2 = 1410$$

$$s_2 = \frac{vt_4}{2} + 133$$

$$s_1 = 1410 - s_2$$

$$s_1 = 1410 - \frac{vt_4}{2} + 133$$

$$s_1 = 1410 - \frac{340 \times 2.7}{2} + 133$$

$$s_1 = 818 \text{ m}$$

.....

.....

Mark	Criteria
2	Correctly calculates distance
1	Shows appropriate expressions for displacements

**Question 31** (5 marks)

In the electrical circuit below the reading on the voltmeter is 6 V.

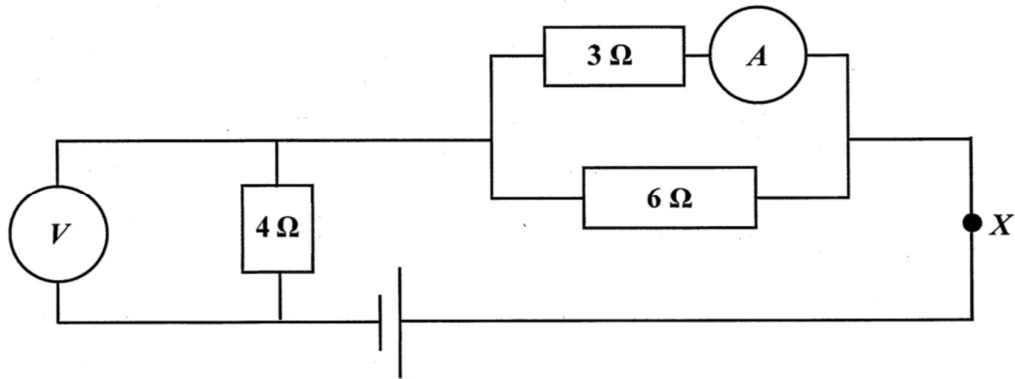

a) What is the total resistance of this circuit?

1

$$\frac{1}{R_{\text{parallel}}} = \frac{1}{3} + \frac{1}{6} \quad R_{\text{parallel}} = 2 \Omega \quad \text{Total circuit resistance} = 4 + 2 = 6 \Omega$$

Mark	Criteria
1	Calculates total resistance

b) What voltage is supplied by the battery?

1

$$\text{Current in } 4 \Omega \text{ resistor} = \frac{V}{R} = \frac{6}{4} = 1.5 \text{ A} \quad V_{\text{total}} = 1.5 \times R_{\text{total}} = 9 \text{ V}$$

Mark	Criteria
1	Calculates voltage from battery

c) What is the reading on the ammeter?

1

$$V \text{ across } 3 \Omega = 9 - 6 = 3 \text{ V} \quad \text{Current in } 3 \Omega = \frac{3}{3} = 1 \text{ A}$$

Mark	Criteria
1	Calculates ammeter reading

d) On the diagram, clearly draw the current direction at point X.

1

Mark	Criteria
1	Shows circuit current direction upwards of X

e) Compare the relative resistance of ammeters and voltmeters

1

Sample Answer: The resistance of an ammeter is extremely low whilst the resistance of a voltmeter is high.

Mark	Criteria
1	Provides correct comparison of resistance

**Question 32** (3 marks)

The total mass of a freight train is  $4.5 \times 10^6$  kg. A section of straight track has a grade of 1:110 (i.e., it rises a vertical distance of 1 m from every 110 m horizontal).

Calculate the power the locomotive needs to supply to haul this train up the slope at  $5.0 \text{ m s}^{-1}$ .

**3**

Answer: First find the angle of the slope then calculate the component of the weight force parallel to the slope the locomotive has to overcome

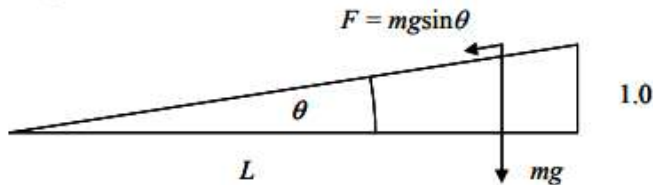

$$\tan \theta = \frac{1}{110}, \therefore \theta = 0.52086^\circ$$

$$F = mg \sin \theta = (4500 \times 10^3) \times 9.8 \times \sin(0.52086^\circ) = 400893 \text{ N}$$

$$\text{Now power} = \text{force} \times \text{velocity} = 400893 \times 5.0 = 2.00 \times 10^6 \text{ W}$$

Mark	Criteria
3	Correctly calculates the power of the locomotive
2	Calculates a power of the locomotive with an omission or error in working out OR Shows significant progress to calculating the power of the locomotive
1	Shows some relevant working

