



Girraween High School

| | | | | | | | | | |
|-------------------|--|--|--|--|--|--|--|--|--|
| Student Number | | | | | | | | | |
|-------------------|--|--|--|--|--|--|--|--|--|

2020 YEAR 11 EXAMINATION

Chemistry

**General
Instructions**

- Reading time – 5 minutes
- Working time – 2 hours
- Write using black pen
- Draw diagrams using pencil
- Calculators approved by NESA may be used

**Total Marks:
75**

Section I – 15 marks (pages 1 – 6)

- Attempt questions 1–15
- Allow about 20 minutes for this part

Section II – 60 marks (pages 7 – 17)

- Attempt questions 16 – 30
- Allow about 1 hour and 40 minutes for this part

Section I

15 marks

Attempt Questions 1–15

Allow about 35 minutes for this part

Use the multiple-choice answer sheet for Question 1–15.

- Which technique would most easily be used to separate a mixture of partly crushed rock particles and sand?
 - Filtration
 - Separating funnel
 - Sieving
 - Sedimentation and decanting
- A 1.00 kilogram packet of sodium hydrogen carbonate (NaHCO_3) is added to the water in a swimming pool to balance the pH of the system.

What is the number of moles of this compound in the 1.00 kilogram packet?

- 0.80
 - 1.20
 - 8.40
 - 11.9
- For many years, Indigenous Australians have employed chemical processes to purify and prepare foods. The fruit of the cycad plant (*Macrozamia*) was an important food source despite it being highly toxic and carcinogenic. Leaching the fruit of the cycads is a part of the purifying process that involves grounding the kernels and allowing it to soak in water.

Leaching aids purification of toxic substances as:

- the water neutralises the toxins.
- grounding the kernels changes the chemical composition of the toxins.
- the water washes out the toxins.
- the water provides the activation energy required for the neutralisation of toxins.

4. Consider the following statements.

- I – the number of atoms can be increased
- II – the number of atoms can be decreased
- III – the atoms can be rearranged
- IV – atoms can gain electrons
- V – atoms can lose electrons

Which of the statements above describe changes that can occur during a chemical reaction?

- (A) I, II and III
- (B) III, IV and V
- (C) III only
- (D) IV and V only

5. An eye dropper solution is made of saline by dissolving pure sodium chloride (NaCl) in distilled water. A 20.0 mL dispenser of eye drops contains 1.5 milligrams of sodium chloride.

What is the concentration of sodium chloride solution in the dispenser?

- (A) $1.3 \times 10^{-3} \text{ mol L}^{-1}$
- (B) $2.6 \times 10^{-2} \text{ mol L}^{-1}$
- (C) $3.9 \times 10^{-2} \text{ mol L}^{-1}$
- (D) $5.1 \times 10^{-1} \text{ mol L}^{-1}$

6. What is the formula of aluminium phosphide?

- (A) AlP
- (B) Al_2P_3
- (C) AlPO_4
- (D) Al_3P_3

7. Consider the elements in the second period of the periodic table.

What is the general trend in the first ionisation energy of these elements?

- (A) Decreases from lithium to neon
- (B) Decreases from lithium to carbon then increases to neon
- (C) Increases from lithium to carbon then decreases to neon
- (D) Increases from lithium to neon

8. What is the oxidation state of arsenic in the arsenate ion, AsO_4^{3-} ?

- (A) -2
- (B) -3
- (C) +4
- (D) +5

9. The Lewis electron dot diagram of boron trifluoride (BF_3) is shown.

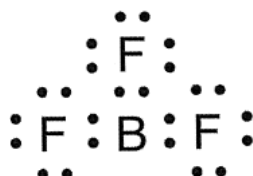

Which of the following is correct for this molecule?

| | <i>Molecular polarity</i> | <i>Molecular shape</i> |
|-----|---------------------------|------------------------|
| (A) | Non-polar | Trigonal planar |
| (B) | Non-polar | Tetrahedral |
| (C) | Polar | Trigonal planar |
| (D) | Polar | Pyramidal |

10. Which of the following equations involving oxides of nitrogen represents a synthesis reaction?

- (A) $2\text{NO}(g) + \text{O}_2(g) \rightarrow 2\text{NO}_2(g)$
- (B) $\text{NO}(g) + \text{CO}_2(g) \rightarrow \text{NO}_2(g) + \text{CO}(g)$
- (C) $2\text{NO}(g) \rightarrow \text{N}_2(g) + 2\text{O}_2(g)$
- (D) $\text{N}_2\text{O}_4(g) \rightarrow 2\text{NO}_2(g)$

11. A student electrically connected two galvanic half-cells to measure and compare their reduction potential. The half-cells used were $\text{Ag}(s)/\text{Ag}^+$ and $\text{Sn}(s)/\text{Sn}^{2+}$.

Assuming the investigation was carried out under standard conditions, what is the maximum potential difference the student would expect to measure?

- (A) 0.46 V
- (B) 0.66 V
- (C) 0.94 V
- (D) 1.74 V

12. What would the percentage of magnesium in a sample of magnesium hydroxide be closest to?

- (A) 34 %
- (B) 42 %
- (C) 55 %
- (D) 62 %

13. Nitrogen gas (N_2) reacts exothermically with hydrogen gas to form ammonia gas (NH_3). The structural formulae of these molecules and a table of average bond energies are shown.

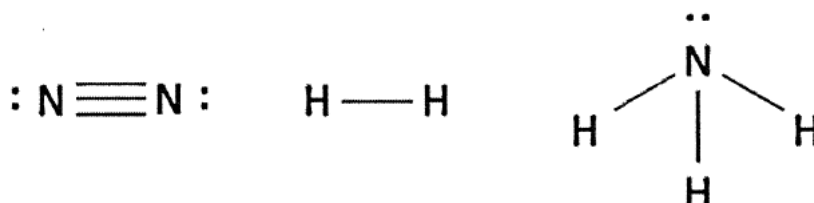

| Bond | Bond energy (kJ mol^{-1}) |
|--------------|--------------------------------------|
| N - H | 391 |
| H - H | 436 |
| N \equiv N | 945 |

Based on this information, what is the value of the enthalpy change for the following reaction?

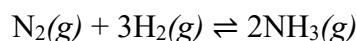

- (A) +93 kJ mol L^{-1}
- (B) -93 kJ mol L^{-1}
- (C) +1080 kJ mol L^{-1}
- (D) -1080 kJ mol L^{-1}

14. Three equations and their ΔH values are shown.

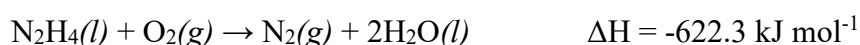

Using this information, what is the ΔH for the following reaction?

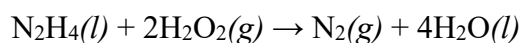

- (A) -532.5 kJ mol^{-1}
- (B) -818.3 kJ mol^{-1}
- (C) -1006.1 kJ mol^{-1}
- (D) -1568.9 kJ mol^{-1}

15. A student performed a practical investigation that involved placing samples of different metals, one of which was lead, into solutions containing ions of other metals represented by the letters X, Y and Z. The results of this investigation are shown in the table below.

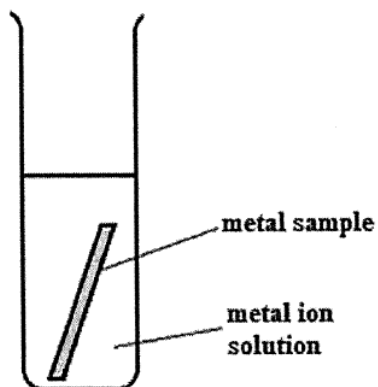

Results table

| Metal | Solution | | | |
|-------|----------|-----------|----------|----------|
| | X^{2+} | Pb^{2+} | Y^{2+} | Z^{2+} |
| X | - | × | × | × |
| Pb | ✓ | - | × | × |
| Y | ✓ | ✓ | - | ✓ |
| Z | ✓ | ✓ | × | - |

- ✓ Indicates a reaction took place
 × Indicates that no reaction took place

Which of the following combinations of metal and metal ions would give the highest potential difference in an electrochemical cell constructed under standard conditions?

- (A) Z and Pb^{2+}
 (B) Pb and X^{2+}
 (C) Z and X^{2+}
 (D) Y and X^{2+}

End of Section I

Instructions for answering questions in Section I

- Complete your answers in either blue or black pen
- Multiple choice

Select the alternative A, B, C or D that best answers the question. Fill in the response oval completely.

Sample 1: $2 + 4 =$ (A) 2 (B) 6 (C) 8 (D) 9
 A B C D

If you think you have made a mistake, put a cross through the incorrect answer and fill in the new answer.

A B C D

If you change your mind and have crossed out what you consider to be the correct answer, then indicate the correct answer by writing the word *correct* and drawing an arrow as follows.

A B C D
 correct

Chemistry Section I – Multiple Choice Answer Sheet

- | | | | | |
|-----|-------------------------|-------------------------|-------------------------|-------------------------|
| 1. | A <input type="radio"/> | B <input type="radio"/> | C <input type="radio"/> | D <input type="radio"/> |
| 2. | A <input type="radio"/> | B <input type="radio"/> | C <input type="radio"/> | D <input type="radio"/> |
| 3. | A <input type="radio"/> | B <input type="radio"/> | C <input type="radio"/> | D <input type="radio"/> |
| 4. | A <input type="radio"/> | B <input type="radio"/> | C <input type="radio"/> | D <input type="radio"/> |
| 5. | A <input type="radio"/> | B <input type="radio"/> | C <input type="radio"/> | D <input type="radio"/> |
| 6. | A <input type="radio"/> | B <input type="radio"/> | C <input type="radio"/> | D <input type="radio"/> |
| 7. | A <input type="radio"/> | B <input type="radio"/> | C <input type="radio"/> | D <input type="radio"/> |
| 8. | A <input type="radio"/> | B <input type="radio"/> | C <input type="radio"/> | D <input type="radio"/> |
| 9. | A <input type="radio"/> | B <input type="radio"/> | C <input type="radio"/> | D <input type="radio"/> |
| 10. | A <input type="radio"/> | B <input type="radio"/> | C <input type="radio"/> | D <input type="radio"/> |
| 11. | A <input type="radio"/> | B <input type="radio"/> | C <input type="radio"/> | D <input type="radio"/> |
| 12. | A <input type="radio"/> | B <input type="radio"/> | C <input type="radio"/> | D <input type="radio"/> |
| 13. | A <input type="radio"/> | B <input type="radio"/> | C <input type="radio"/> | D <input type="radio"/> |
| 14. | A <input type="radio"/> | B <input type="radio"/> | C <input type="radio"/> | D <input type="radio"/> |
| 15. | A <input type="radio"/> | B <input type="radio"/> | C <input type="radio"/> | D <input type="radio"/> |

| | | | | | | | | |
|------------------|--|--|--|--|--|--|--|--|
| Student Number | | | | | | | | |
| Section I / 15 | | | | | | | | |
| Section II / 60 | | | | | | | | |
| Total /75 | | | | | | | | |

**Chemistry
Section II****60 marks****Attempt Questions 16 – 30****Allow about 1 hours 40 minutes for this section**

Instructions

- Write your student number at the top of this page.
- Answer the questions in the spaces provided. These spaces provide guidance for the expected length of the response.
- Show all relevant working in questions involving calculations
- Extra writing paper is available, please raise your hand to request more paper. If you use extra paper, clearly indicate your student number and which question you are answering.

Please turn over

Question 16 (2 marks)

A sample of carbon dioxide gas has a volume of 21.5 mL. If the temperature of the gas is raised from 50.0°C to 75.0°C, find the new volume of the gas, assuming a constant pressure. **2**

.....

.....

.....

Question 17 (8 marks)

(a) Draw a Lewis electron dot diagram for each of the following compounds.

i. CF₄ **1**

ii. CaCl₂ **1**

(b) Using the two substances in (a) as examples, compare the bonding in ionic compounds with the bonding in covalent molecular compounds. **3**

.....

.....

.....

.....

.....

- (c) The boiling point of CF_4 -127.8°C , and the boiling point of CaCl_2 is 1935°C . Account for the difference in boiling points between these two substances. **3**

.....

.....

.....

.....

.....

Question 18 (4 marks)

A piece of magnesium weighing 2.40 g is placed into a beaker containing 400.0 mL of $0.5000 \text{ mol L}^{-1}$ of hydrochloric acid.

- (a) Determine the limiting reagent (show all working). **2**

.....

.....

.....

.....

.....

.....

- (b) Calculate the volume of gas produced in this reaction, at 25°C and 100 kPa. **2**

.....

.....

.....

.....

Question 19 (4 marks)

Consider the chemical reagents listed below.

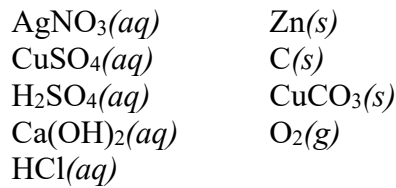

Using only the chemicals from the list above as reactants, and using each chemical only **once**, write chemical equations to represent each of the following types of reactions.

(a) An acid and a metal reaction.

1

.....

(b) A combustion reaction.

1

.....

(c) An acid and a carbonate reaction.

1

.....

(d) A precipitation reaction.

1

.....

Question 20 (3 marks)

Some ethanol is burned in a spirit burner. The combustion of 1.275 g of ethanol ($\text{C}_2\text{H}_5\text{OH}$) raises the temperature of 100.0 g of water by 14.4°C . The enthalpy of combustion of ethanol is 1367 kJ mol^{-1} . Assume complete combustion of ethanol and no evaporation of water.

Calculate the percentage of heat loss in this experiment.

3

.....
.....
.....
.....

Question 21 (5 marks)

The element antimony is a shiny, silvery-white element used to make certain types of semiconductor devices.

- (a) Antimony has three unstable allotropes and many unstable isotopes. Distinguish between the term allotrope and isotope. **2**

.....

.....

.....

- (b) Antimony has two naturally occurring, stable isotopes that contribute to its average atomic mass. One of these isotopes, ^{121}Sb , has a percentage abundance of 57.21%. Calculate the mass of the other isotope. **2**

.....

.....

.....

- (c) One of the unstable isotopes of antimony is ^{125}Sb . Write an equation for the nuclear decomposition of this isotope when it undergoes beta decay. **1**

.....

Question 22 (4 marks)

The compound copper sulfate pentahydrate has the formula $\text{CuSO}_4 \cdot 5\text{H}_2\text{O}$.

- (a) A student makes a solution of this compound by dissolving 50.0 g in 500.0 mL of distilled water. Calculate the concentration of this solution. **2**

.....
.....
.....
.....

- (b) The student now requires 1.0 L of a 1.0% (w/v) solution. What volume of the solution in part (a) is required to make this? **2**

.....
.....
.....
.....
.....

Question 23 (3 marks)

When aqueous solutions of Fe^{3+} and SCN^- are mixed the following exothermic reaction occurs:

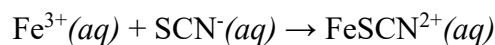

- The temperature of the reacting mixture is increased. Predict the effect of this change on the Gibbs free energy and on the spontaneity of the reaction by referring to the enthalpy and the entropy of the reaction. **3**

.....
.....
.....
.....
.....

Question 24 (7 marks)

A galvanic cell has been constructed as shown in the diagram below.

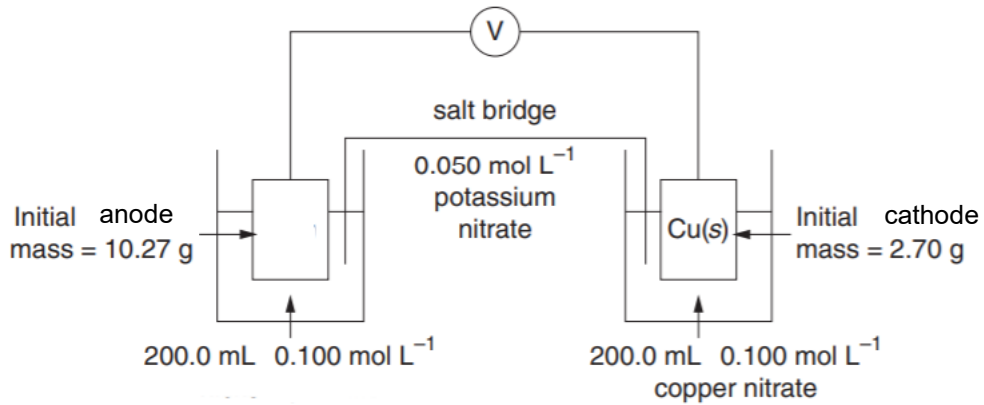

- (a) The standard potential for this reaction is 0.58 V. 2

Use half equations to identify the unknown electrode.

.....

.....

.....

.....

.....

- (b) The unknown solution is a green colour. Explain the colour change in this half-cell as the reaction proceeds. 2

.....

.....

.....

- (c) After a period of time, a solid deposit that had formed on the copper electrode was removed and dried. The deposit had a mass of 0.175 g. Calculate the final concentration of the copper nitrate solution. 3

.....

.....

.....

Question 25 (4 marks)

Below is the energy profile diagram for a chemical reaction.

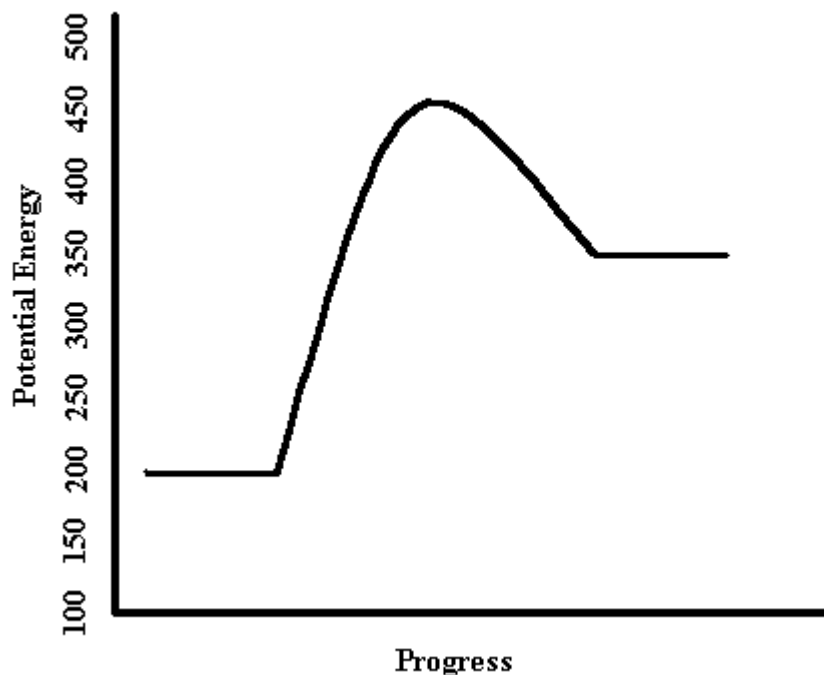

- (a) Determine the enthalpy for the reaction above and state whether it is exothermic or endothermic. 2

.....

- (b) Determine the activation energy for the reaction above. 1

.....

- (c) Show what would happen if a catalyst was added to the reaction by drawing on the diagram. 1

Question 26 (3 marks)

An organic halide, on analysis, is determined to have the following composition:

C 37.5% H 3.1% F 59.4%

(a) Calculate the empirical formula of this compound.

2

.....
.....
.....
.....
.....

(b) If the relative molecular mass of this compound is 94, determine the molecular formula of this compound.

1

.....
.....
.....
.....

Question 27 (2 marks)

The reduction of copper(II) oxide takes place as follows:

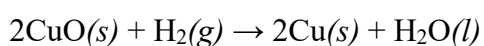

$$\begin{aligned} \Delta H &= 58.1 \text{ kJ mol}^{-1} \\ \Delta S &= 165 \text{ J mol}^{-1} \text{ K}^{-1} \end{aligned}$$

Predict the temperature at which this reaction will become spontaneous. Show your working.

2

.....
.....
.....
.....
.....
.....

Question 28 (4 marks)

Magnesium and magnesium oxide both conduct electricity in the molten state. However, magnesium also conducts electricity in the solid state, whereas magnesium oxide does not. Explain the electrical conductivity of magnesium and magnesium oxide in terms of their structure and bonding.

4

.....

.....

.....

.....

.....

.....

.....

.....

.....

.....

.....

.....

.....

.....

.....

.....

.....

.....

.....

.....

.....

.....

Question 29 (2 marks)

Write the electronic configuration for the following substances, using spdf notation.

(a) Neon atom

..... **1**

(b) Chloride ion

..... **1**

Question 30 (6 marks)

A student was given a mixture of copper sulfate crystals, iron filings, and zinc oxide powder. Below is a table of the properties of these substances.

| <i>Substance</i> | <i>Formula</i> | <i>Melting Point (°C)</i> | <i>Solubility</i> | <i>Density (g cm⁻³)</i> |
|------------------|-------------------|---------------------------|-------------------|------------------------------------|
| Copper sulfate | CuSO ₄ | 110 | Very soluble | 3.6 |
| Iron filings | Fe | 1538 | Insoluble | 7.9 |
| Zinc oxide | ZnO | 1974 | Insoluble | 5.1 |

- (a) Identify whether you would expect this mixture to be a homogenous mixture or a heterogenous mixture and explain why. **3**

.....

.....

.....

.....

.....

- (b) Draw a flow diagram that shows how one could effectively separate this mixture to collect pure samples of each of the three substances. **3**

End of Examination



Girraween High School

| | | | | | | | | | |
|-------------------|--|--|--|--|--|--|--|--|--|
| Student Number | | | | | | | | | |
|-------------------|--|--|--|--|--|--|--|--|--|

2020 YEAR 11 EXAMINATION

Chemistry

**General
Instructions**

- Reading time – 5 minutes
- Working time – 2 hours
- Write using black pen
- Draw diagrams using pencil
- Calculators approved by NESAs may be used

**Total Marks:
75**

Section I – 15 marks (pages 1 – 6)

- Attempt questions 1–15
- Allow about 20 minutes for this part

Section II – 60 marks (pages 7 – 17)

- Attempt questions 16 – 30
- Allow about 1 hour and 40 minutes for this part

Section I

15 marks

Attempt Questions 1–15

Allow about 35 minutes for this part

Use the multiple-choice answer sheet for Question 1–15.

- Which technique would most easily be used to separate a mixture of partly crushed rock particles and sand?
 - Filtration
 - Separating funnel
 - Sieving
 - Sedimentation and decanting
- A 1.00 kilogram packet of sodium hydrogen carbonate (NaHCO_3) is added to the water in a swimming pool to balance the pH of the system.

What is the number of moles of this compound in the 1.00 kilogram packet?

- 0.80
 - 1.20
 - 8.40
 - 11.9
- For many years, Indigenous Australians have employed chemical processes to purify and prepare foods. The fruit of the cycad plant (*Macrozamia*) was an important food source despite it being highly toxic and carcinogenic. Leaching the fruit of the cycads is a part of the purifying process that involves grounding the kernels and allowing it to soak in water.

Leaching aids purification of toxic substances as:

- the water neutralises the toxins.
- grounding the kernels changes the chemical composition of the toxins.
- the water washes out the toxins.
- the water provides the activation energy required for the neutralisation of toxins.

4. Consider the following statements.

- I – the number of atoms can be increased
- II – the number of atoms can be decreased
- III – the atoms can be rearranged
- IV – atoms can gain electrons
- V – atoms can lose electrons

Which of the statements above describe changes that can occur during a chemical reaction?

- (A) I, II and III
- (B) III, IV and V
- (C) III only
- (D) IV and V only

5. An eye dropper solution is made of saline by dissolving pure sodium chloride (NaCl) in distilled water. A 20.0 mL dispenser of eye drops contains 1.5 milligrams of sodium chloride.

What is the concentration of sodium chloride solution in the dispenser?

- (A) $1.3 \times 10^{-3} \text{ mol L}^{-1}$
- (B) $2.6 \times 10^{-2} \text{ mol L}^{-1}$
- (C) $3.9 \times 10^{-2} \text{ mol L}^{-1}$
- (D) $5.1 \times 10^{-1} \text{ mol L}^{-1}$

6. What is the formula of aluminium phosphide?

- (A) AlP
- (B) Al_2P_3
- (C) AlPO_4
- (D) Al_3P_3

7. Consider the elements in the second period of the periodic table.

What is the general trend in the first ionisation energy of these elements?

- (A) Decreases from lithium to neon
- (B) Decreases from lithium to carbon then increases to neon
- (C) Increases from lithium to carbon then decreases to neon
- (D) Increases from lithium to neon

8. What is the oxidation state of arsenic in the arsenate ion, AsO_4^{3-} ?

- (A) -2
- (B) -3
- (C) +4
- (D) +5

9. The Lewis electron dot diagram of boron trifluoride (BF_3) is shown.

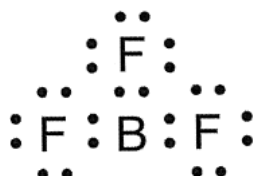

Which of the following is correct for this molecule?

| | <i>Molecular polarity</i> | <i>Molecular shape</i> |
|-----|---------------------------|------------------------|
| (A) | Non-polar | Trigonal planar |
| (B) | Non-polar | Tetrahedral |
| (C) | Polar | Trigonal planar |
| (D) | Polar | Pyramidal |

10. Which of the following equations involving oxides of nitrogen represents a synthesis reaction?

- (A) $2\text{NO}(g) + \text{O}_2(g) \rightarrow 2\text{NO}_2(g)$
- (B) $\text{NO}(g) + \text{CO}_2(g) \rightarrow \text{NO}_2(g) + \text{CO}(g)$
- (C) $2\text{NO}(g) \rightarrow \text{N}_2(g) + 2\text{O}_2(g)$
- (D) $\text{N}_2\text{O}_4(g) \rightarrow 2\text{NO}_2(g)$

11. A student electrically connected two galvanic half-cells to measure and compare their reduction potential. The half-cells used were $\text{Ag}(s)/\text{Ag}^+$ and $\text{Sn}(s)/\text{Sn}^{2+}$.

Assuming the investigation was carried out under standard conditions, what is the maximum potential difference the student would expect to measure?

- (A) 0.46 V
- (B) 0.66 V
- (C) 0.94 V
- (D) 1.74 V

12. What would the percentage of magnesium in a sample of magnesium hydroxide be closest to?

- (A) 34 %
- (B) 42 %
- (C) 55 %
- (D) 62 %

13. Nitrogen gas (N_2) reacts exothermically with hydrogen gas to form ammonia gas (NH_3). The structural formulae of these molecules and a table of average bond energies are shown.

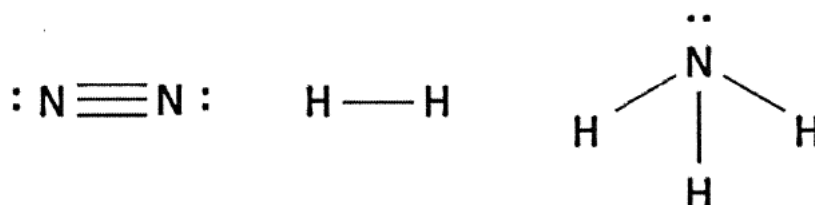

| Bond | Bond energy (kJ mol^{-1}) |
|--------------|--------------------------------------|
| N - H | 391 |
| H - H | 436 |
| N \equiv N | 945 |

Based on this information, what is the value of the enthalpy change for the following reaction?

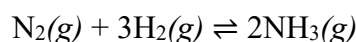

- (A) $+93 \text{ kJ mol}^{-1}$
- (B) -93 kJ mol^{-1}
- (C) $+1080 \text{ kJ mol}^{-1}$
- (D) $-1080 \text{ kJ mol}^{-1}$

14. Three equations and their ΔH values are shown.

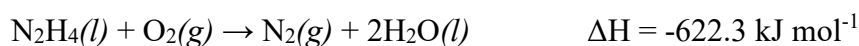

Using this information, what is the ΔH for the following reaction?

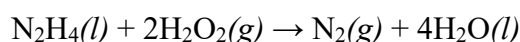

- (A) $-532.5 \text{ kJ mol}^{-1}$
- (B) $-818.3 \text{ kJ mol}^{-1}$
- (C) $-1006.1 \text{ kJ mol}^{-1}$
- (D) $-1568.9 \text{ kJ mol}^{-1}$

15. A student performed a practical investigation that involved placing samples of different metals, one of which was lead, into solutions containing ions of other metals represented by the letters X, Y and Z. The results of this investigation are shown in the table below.

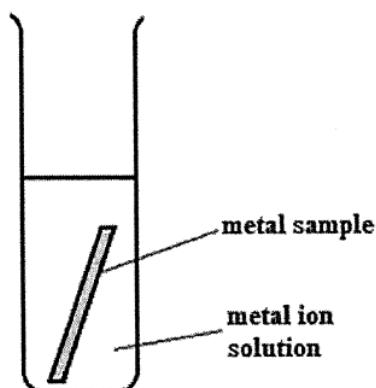

Results table

| Metal | Solution | | | |
|-------|-----------------|------------------|-----------------|-----------------|
| | X ²⁺ | Pb ²⁺ | Y ²⁺ | Z ²⁺ |
| X | - | × | × | × |
| Pb | ✓ | - | × | × |
| Y | ✓ | ✓ | - | ✓ |
| Z | ✓ | ✓ | × | - |

- ✓ Indicates a reaction took place
 × Indicates that no reaction took place

Which of the following combinations of metal and metal ions would give the highest potential difference in an electrochemical cell constructed under standard conditions?

- (A) Z and Pb²⁺
 (B) Pb and X²⁺
 (C) Z and X²⁺
 (D) Y and X²⁺

End of Section I

Instructions for answering questions in Section I

- Complete your answers in either blue or black pen
- Multiple choice

Select the alternative A, B, C or D that best answers the question. Fill in the response oval completely.

Sample 1: $2 + 4 =$ (A) 2 (B) 6 (C) 8 (D) 9
 A B C D

If you think you have made a mistake, put a cross through the incorrect answer and fill in the new answer.

A B C D

If you change your mind and have crossed out what you consider to be the correct answer, then indicate the correct answer by writing the word *correct* and drawing an arrow as follows.

A B C D
 correct

Chemistry Section I – Multiple Choice Answer Sheet

- | | | | | |
|-----|-------------------------|-------------------------|-------------------------|-------------------------|
| 1. | A <input type="radio"/> | B <input type="radio"/> | C <input type="radio"/> | D <input type="radio"/> |
| 2. | A <input type="radio"/> | B <input type="radio"/> | C <input type="radio"/> | D <input type="radio"/> |
| 3. | A <input type="radio"/> | B <input type="radio"/> | C <input type="radio"/> | D <input type="radio"/> |
| 4. | A <input type="radio"/> | B <input type="radio"/> | C <input type="radio"/> | D <input type="radio"/> |
| 5. | A <input type="radio"/> | B <input type="radio"/> | C <input type="radio"/> | D <input type="radio"/> |
| 6. | A <input type="radio"/> | B <input type="radio"/> | C <input type="radio"/> | D <input type="radio"/> |
| 7. | A <input type="radio"/> | B <input type="radio"/> | C <input type="radio"/> | D <input type="radio"/> |
| 8. | A <input type="radio"/> | B <input type="radio"/> | C <input type="radio"/> | D <input type="radio"/> |
| 9. | A <input type="radio"/> | B <input type="radio"/> | C <input type="radio"/> | D <input type="radio"/> |
| 10. | A <input type="radio"/> | B <input type="radio"/> | C <input type="radio"/> | D <input type="radio"/> |
| 11. | A <input type="radio"/> | B <input type="radio"/> | C <input type="radio"/> | D <input type="radio"/> |
| 12. | A <input type="radio"/> | B <input type="radio"/> | C <input type="radio"/> | D <input type="radio"/> |
| 13. | A <input type="radio"/> | B <input type="radio"/> | C <input type="radio"/> | D <input type="radio"/> |
| 14. | A <input type="radio"/> | B <input type="radio"/> | C <input type="radio"/> | D <input type="radio"/> |
| 15. | A <input type="radio"/> | B <input type="radio"/> | C <input type="radio"/> | D <input type="radio"/> |

| | | | | | | | | |
|------------------|--|--|--|--|--|--|--|--|
| Student Number | | | | | | | | |
| Section I / 15 | | | | | | | | |
| Section II / 60 | | | | | | | | |
| Total /75 | | | | | | | | |

**Chemistry
Section II****60 marks****Attempt Questions 16 – 30****Allow about 1 hours 40 minutes for this section**

Instructions

- Write your student number at the top of this page.
- Answer the questions in the spaces provided. These spaces provide guidance for the expected length of the response.
- Show all relevant working in questions involving calculations
- Extra writing paper is available, please raise your hand to request more paper. If you use extra paper, clearly indicate your student number and which question you are answering.

Please turn over

Question 16 (2 marks)

A sample of carbon dioxide gas has a volume of 21.5 mL. If the temperature of the gas is raised from 50.0°C to 75.0°C, find the new volume of the gas, assuming a constant pressure. 2

$$\frac{V_1}{T_1} = \frac{V_2}{T_2}$$

$$V_2 = \frac{V_1 T_2}{T_1} = \frac{0.0215 \times (75 + 273.15)}{(50 + 273.15)} = 23.16 \text{ mL}$$

Question 17 (8 marks)

(a) Draw a Lewis electron dot diagram for each of the following compounds.

i. CF₄ 1

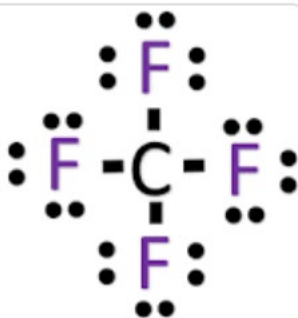

ii. CaCl₂ 1



(b) Using the two substances in (a) as examples, compare the bonding in ionic compounds with the bonding in covalent molecular compounds. 3

Ionic compounds are solids at STP and consist of positively and negatively ions held together in a lattice by strong electrostatic forces. In calcium chloride doubly charged calcium cations are surrounded by chloride anions in a ratio of 1:2.

Covalent molecular compounds are groups of atoms in which one or more pairs of electrons are shared between atoms. In carbon tetrafluoride all of carbon's valence electrons are shared with each of the fluorine's electrons to form four covalent bonds. Carbon tetrafluoride molecules are bound together by relatively weak intermolecular forces and form a gas at STP.

(c) The boiling point of CF₄ -127.8°C, and the boiling point of CaCl₂ is 1935°C. Account for the difference in boiling points between these two substances. 3

Question 18 (4 marks)

A piece of magnesium weighing 2.40 g is placed into a beaker containing 400.0 mL of 0.5000 mol L⁻¹ of hydrochloric acid.

(a) Determine the limiting reagent (show all working).

2

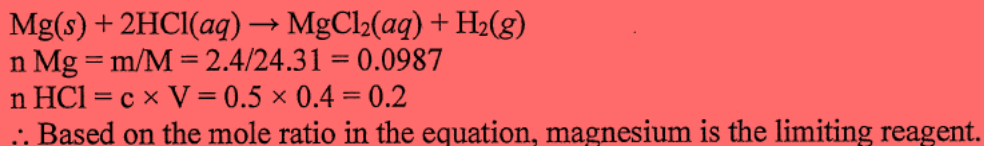

| Marking Criteria | Mark |
|---|------|
| • Uses correct calculations to show that magnesium is the limiting reagent | 2 |
| • Uses a logical calculation to show that magnesium is the limiting reagent | 1 |

2

(b) Calculate the volume of gas produced in this reaction, at 25°C and 100 kPa.

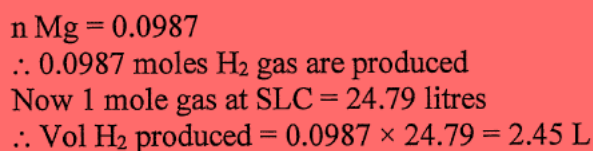

| Marking Criteria | Mark |
|---|------|
| • Calculates the correct volume of gas produced under standard lab conditions | 1 |

Question 19 (4 marks)

Consider the chemical reagents listed below.

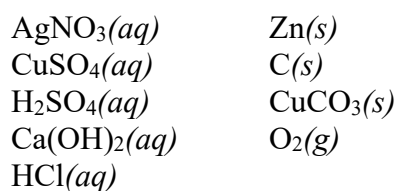

Using only the chemicals from the list above as reactants, and using each chemical only **once**, write chemical equations to represent each of the following types of reactions.

(a) An acid and a metal reaction.

1

| Criteria | Mark |
|--|------|
| • Writes an appropriate, correctly balanced acid on carbonate equation | 1 |

Sample answer: $2\text{HCl}(aq) + \text{CuCO}_3(s) \rightarrow \text{CuCl}_2(aq) + \text{H}_2\text{O}(l) + \text{CO}_2(g)$

(b) A combustion reaction.

1

| Criteria | Mark |
|---|------|
| • Writes an appropriate, correctly balanced combustion equation | 1 |
| <i>Sample answer:</i> $C(s) + O_2(g) \rightarrow CO_2(g)$ | |

(c) An acid and a carbonate reaction.

1

| Criteria | Mark |
|---|------|
| • Writes an appropriate, correctly balanced acid on carbonate equation | 1 |
| <i>Sample answer:</i> $2HCl(aq) + CuCO_3(s) \rightarrow CuCl_2(aq) + H_2O(l) + CO_2(g)$ | |

(d) A precipitation reaction.

1

| Criteria | Mark |
|---|------|
| • Writes an appropriate, correctly balanced precipitation equation | 1 |
| <i>Sample answer:</i> $CuSO_4(aq) + 2AgNO_3(aq) \rightarrow Ag_2SO_4(s) + Cu(NO_3)_2(aq)$ | |

Question 20 (3 marks)

Some ethanol is burned in a spirit burner. The combustion of 1.275 g of ethanol (C_2H_5OH) raises the temperature of 100.0 g of water by $14.4^\circ C$. The enthalpy of combustion of ethanol is $-1367 \text{ kJ mol}^{-1}$. Assume complete combustion of ethanol and no evaporation of water.

Calculate the percentage of heat loss in this experiment.

3

$$\begin{aligned}q_{\text{absorbed by water}} &= mC\Delta T = 100 \times 4.18 \times 14.4 = 6.0192 \text{ kJ} \\n_{\text{ethanol combusted}} &= \frac{m}{MM} = \frac{1.275}{46.068} = 2.77 \times 10^{-2} \text{ mol} \\q_{\text{released by ethanol}} &= 1367 \times (2.77 \times 10^{-2}) = 37.834 \text{ kJ} \\q_{\text{lost}} &= 37.834 - 6.0192 = 31.815 \text{ kJ} \\\therefore \% \text{ of } q_{\text{lost}} &= \frac{31.815}{37.834} \times 100 = 84.1 \%\end{aligned}$$

| Marking Criteria | Mark |
|--|------|
| <ul style="list-style-type: none">• Calculates the correct amount of heat absorbed by water• Calculates the correct number of moles of ethanol combusted AND Calculates the correct amount of heat released by the number of moles of ethanol combusted in the reaction• Calculates the correct amount of heat loss, hence the percentage of the heat loss | 3 |

Question 21 (5 marks)

The element antimony is a shiny, silvery-white element used to make certain types of semiconductor devices.

- (a) Antimony has three unstable allotropes and many unstable isotopes. Distinguish between the term allotrope and isotope. 2

No solution provided

- (b) Antimony has two naturally occurring, stable isotopes that contribute to its average atomic mass. One of these isotopes, ^{121}Sb , has a percentage abundance of 57.21%. Calculate the mass of the other isotope. 2

No solution provided

- (c) One of the unstable isotopes of antimony is ^{125}Sb . Write an equation for the nuclear decomposition of this isotope when it undergoes beta decay. 1

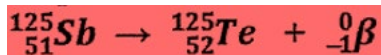

| Marking Criteria | Mark |
|--|------|
| • Correctly writes the nuclear equation for the beta decay | 1 |

Question 22 (4 marks)

The compound copper sulfate pentahydrate has the formula $\text{CuSO}_4 \cdot 5\text{H}_2\text{O}$.

- (a) A student makes a solution of this compound by dissolving 50.0 g in 500.0 mL of distilled water. Calculate the concentration of this solution. 2

$$\begin{aligned} \text{MM} &= 63.55 + 32.07 + (16 \times 4) + (1.008 \times 10) + (16 \times 5) = 249.7 \text{ g} \\ n &= m/\text{MM} = 50.0/249.7 = 0.20 \text{ mole} \\ c &= n/V = 0.20/0.5 = 0.40 \text{ mol L}^{-1} \end{aligned}$$

| Marking Criteria | Mark |
|---|------|
| • Correctly calculates the concentration of the initial solution. | 2 |
| • Uses a correct formula to calculate the concentration of the initial solution | 1 |

- (b) The student now requires 1.0 L of a 1.0% (w/v) solution. What volume of the solution in part (a) is required to make this? 2

$$\begin{aligned} 1\% \text{ solution} &= 1 \text{ gram solute in } 100 \text{ mL solution} = 1/249.7 \text{ mole} \\ &= 4.0 \times 10^{-3} \text{ moles} \\ \text{Now } c &= n/v = 4.0 \times 10^{-3}/0.1 = 0.040 \text{ mol L}^{-1} \\ \text{And } c_1 \times V_1 &= c_2 \times V_2 \\ 0.4 \times V_1 &= 0.04 \times 1 \\ \therefore V_1 &= 0.10 \text{ L} \end{aligned}$$

Question 23 (3 marks)

When aqueous solutions of Fe^{3+} and SCN^- are mixed the following exothermic reaction occurs:

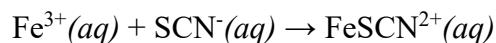

The temperature of the reacting mixture is increased. Predict the effect of this change on the Gibbs free energy and on the spontaneity of the reaction by referring to the enthalpy and the entropy of the reaction. **3**

Gibbs free energy is given by $\Delta G = \Delta H - T\Delta S$.

The reaction is exothermic and so the enthalpy change ΔH would be negative. In this reaction two ions react to form one ion so entropy (S) would be negative. As temperature (T) increases ($-T\Delta S$) would become more positive and this would cause ΔG to increase. The reaction would therefore become less spontaneous.

Common error:

Many said that the entropy increases as the temperature increases, which is true in general, however the entropy of a reaction remains unchanged regardless of the temperature. The entropy of THIS reaction is always going to be negative as the product is more orderly than the reactants (it is a synthesis reaction).

| Marking Criteria | Mark |
|---|------|
| <ul style="list-style-type: none"> States that ΔH is negative since it is given that the reaction is exothermic AND Correctly identifies that the entropy is negative for the reaction as it is a synthesis reaction. (marking code: $\Delta H \Delta S \rightarrow 1$ mark) Correctly explains the effect of increasing the temperature using $\Delta G = \Delta H - T\Delta S$. (marking code: $T \rightarrow 1$ mark) <i>NOTE: the equation must be written to get this mark</i> Correctly predicts that the Gibbs free energy will therefore increase, hence the reaction will become less spontaneous. (marking code: $G S \rightarrow 1$ mark) | 3 |
| <ul style="list-style-type: none"> Any two of the above | 2 |
| <ul style="list-style-type: none"> Any one of the above | 1 |

Question 24 (7 marks)

A galvanic cell has been constructed as shown in the diagram below.

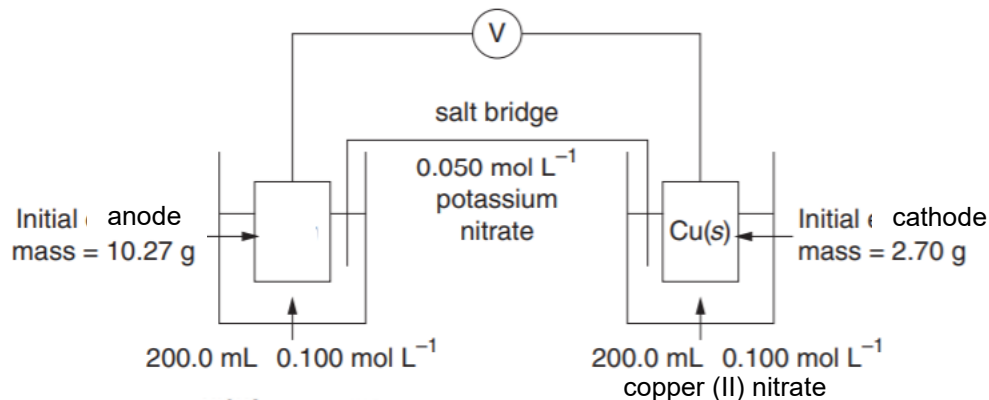

(a) The standard potential for this reaction is 0.58 V.

2

Use half equations to identify the unknown electrode.

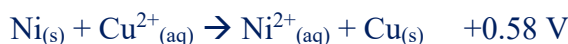

Many did not reverse the sign of E° for the oxidation of Ni (i.e. left it as -0.24 V) OR did not reverse the half equation of Ni shown on the reference sheet. This is incorrect, however no marks have been deducted.

| Marking Criteria | Mark |
|---|------|
| <ul style="list-style-type: none"> Correctly writes the half equation for the reduction of Cu^{2+} Correctly writes the half equation for the oxidation of Ni. OR | 2 |
| <ul style="list-style-type: none"> Correctly uses the potential given in the question to identify the unknown metal is Ni | |
| <ul style="list-style-type: none"> One of the above | 1 |

(b) The unknown solution is a green colour. Explain the colour change in this half-cell as the reaction proceeds.

2

The solution will become darker (more green) as the reaction proceeds. This is due to the oxidation of nickel to form Ni^{2+} ions which release into the solution, hence darkening it.

| Marking Criteria | Mark |
|---|------|
| <ul style="list-style-type: none"> States that the solution will become darker (more green) Correctly explains that the reason is due to more Ni^{2+} releasing into the solution | 2 |
| <ul style="list-style-type: none"> One of the above | 1 |

- (c) After a period of time, a solid deposit that had formed on the copper electrode was removed and dried. The deposit had a mass of 0.175 g. Calculate the final concentration of the copper nitrate solution. 3

$$n_{\text{Cu(s)formed}} = \frac{0.175}{63.55} = 2.75 \times 10^{-3} \text{ mol}$$

$$n_{\text{Cu}^{2+} \text{ reduced}} = 2.75 \times 10^{-3} \text{ mol}$$

$$n_{\text{Cu}^{2+} \text{ remaining in solution}} = (0.1 \times 0.2) - (2.75 \times 10^{-3}) = 1.72 \times 10^{-2} \text{ mol}$$

$$\therefore [\text{Cu}^{2+}] = \frac{n}{v} = \frac{1.72 \times 10^{-2}}{0.2} = 0.0862 \text{ molL}^{-1}$$

| Marking Criteria | Mark |
|--|------|
| <ul style="list-style-type: none"> • Correctly calculates $n_{\text{Cu(s)formed}}$ and $n_{\text{Cu}^{2+} \text{ reduced}}$ • Correctly calculates $n_{\text{Cu}^{2+} \text{ remaining in solution}}$ • Hence correctly calculates $[\text{Cu}^{2+}]$ | 3 |

Question 25 (4 marks)

Below is the energy profile diagram for a chemical reaction.

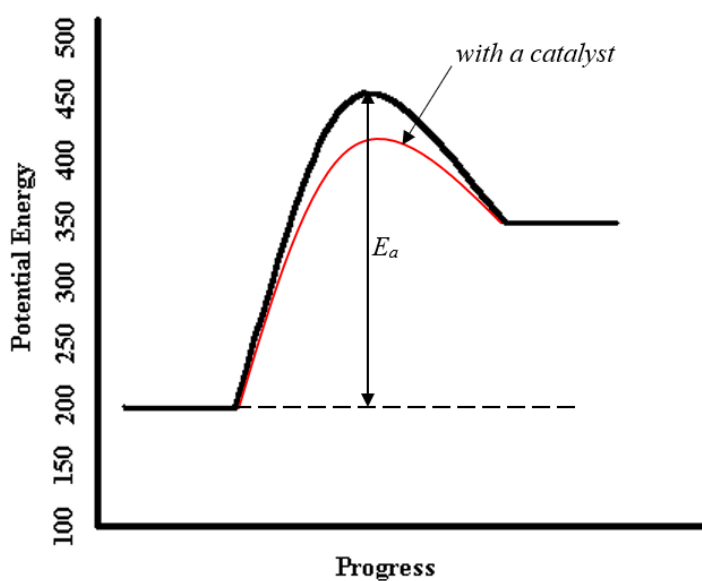

- (a) Determine the enthalpy for the reaction above and state whether it is exothermic or endothermic. 2

$$\Delta H = 350 - 200 = +150 \text{ units}$$

The reaction is endothermic.

| Marking Criteria | Mark |
|---|------|
| <ul style="list-style-type: none"> Determines the correct enthalpy for the reaction. States that it is endothermic. | 2 |
| <ul style="list-style-type: none"> One of the above. | 1 |

(b) Determine the activation energy for the reaction above. 1

$$E_a = 450 - 200 = 250 \text{ units}$$

(c) Show what would happen if a catalyst was added to the reaction by drawing on the diagram. 1

Question 26 (3 marks)

An organic halide, on analysis, is determined to have the following composition:

C 37.5% H 3.1% F 59.4%

(a) Calculate the empirical formula of this compound. 2

$$n_C : n_H : n_F$$

$$\frac{37.5}{12.01} : \frac{3.1}{1.008} : \frac{59.4}{19.00}$$

$$3.122 : 3.075 : 3.126$$

$$\approx 1 : 1 : 1$$

\therefore empirical formula is CHF

| Marking Criteria | Mark |
|--|------|
| <ul style="list-style-type: none"> Calculates the correct molar ratio of C:H:F Determines the correct empirical formula of the compound using the molar ratio calculated | 2 |
| <ul style="list-style-type: none"> One of the above. | 1 |

(b) If the relative molecular mass of this compound is 94, determine the molecular formula of this compound. 1

$$\text{Units of empirical formula} = \frac{94}{(12.01 + 1.008 + 19.00)} = 2.94$$

\therefore molecular formula is approximately $(3 \times \text{empirical formula}) = C_3H_3F_3$

Question 27 (2 marks)

The reduction of copper (II) oxide takes place as follows:

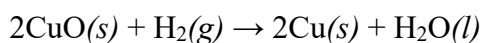

$$\Delta H = 58.1 \text{ kJ mol}^{-1}$$

$$\Delta S = 165 \text{ J mol}^{-1} \text{ K}^{-1}$$

Predict the temperature at which this reaction will become spontaneous. Show your working.

2

$$\Delta G = \Delta H - T\Delta S$$

Reaction becomes spontaneous when $\Delta G < 0$.

$$(58.1 \times 1000) - T(165) < 0$$

$$165T > 58100$$

$$T > 352\text{K}$$

\therefore At the temperature of 352K (= 79°C), the reaction becomes spontaneous.

Feedback: students *should* say that reaction is spontaneous when Gibbs Free Energy is <0 . They should also pay careful attention to units, and convert either the enthalpy of entropy so they match.

| Marking Criteria | Mark |
|--|------|
| <ul style="list-style-type: none"> Substitutes the correct values into the equation, $\Delta G = \Delta H - T\Delta S$ Identifies that $\Delta G < 0$ for spontaneous reactions AND Calculates the correct temperature at which the reaction becomes spontaneous. | 2 |
| <ul style="list-style-type: none"> One of the above. | 1 |

Question 28 (4 marks)

Magnesium and magnesium oxide both conduct electricity in the molten state. However, magnesium also conducts electricity in the solid state, whereas magnesium oxide does not. Explain the electrical conductivity of magnesium and magnesium oxide in terms of their structure and bonding.

4

MgO is an ionic compound where each positive and negative ion is held together by strong electrostatic forces in a rigid ionic lattice. Solid magnesium oxide cannot conduct electricity because there are no mobile ions or electrons present. When MgO is in its molten state, it CAN conduct electricity with the mobile ions that are dissociated in the solution.

Mg is a metal and thus has metallic bonding where each atom is a positive ion surrounded by a delocalised 'sea' of electrons. It is this mobile sea of electrons that allows an electric current to be carried readily through the metal to conduct electricity in both solid and molten state.

Feedback: most students explained metal properly. However, molten MgO – many saying that electrons are free-flowing, but it is the ions that flow freely.

| Marking Criteria | Mark |
|--|------|
| <ul style="list-style-type: none"> Explains the structure of the solid ionic lattice as having no freely moving charges Explains that the structure of the ionic substance in solution/molten has freely moving ions which allows conducting electricity | 4 |

| | |
|---|---|
| <ul style="list-style-type: none"> Explains that metals have metallic bonding so in both molten and solid states they have freely moving electrons due to the nature of their bonding (sea of electrons) | |
| <ul style="list-style-type: none"> Explains the nature of one substance fully, but not the other substance | 3 |
| <ul style="list-style-type: none"> Identifies that the type of bonding correlates to this difference ONLY | 2 |
| <ul style="list-style-type: none"> Some relevant information | 1 |

Question 29 (2 marks)

Write the electronic configuration for the following substances, using spdf notation.

(a) Neon atom

1



(b) Chloride ion

1



Question 30 (6 marks)

A student was given a mixture of copper sulfate crystals, iron filings, and zinc oxide powder. Below is a table of the properties of these substances.

| Substance | Formula | Melting Point (°C) | Solubility | Density (g cm ⁻³) |
|----------------|-------------------|--------------------|--------------|-------------------------------|
| Copper sulfate | CuSO ₄ | 110 | Very soluble | 3.6 |
| Iron filings | Fe | 1538 | Insoluble | 7.9 |
| Zinc oxide | ZnO | 1974 | Insoluble | 5.1 |

(a) Identify whether you would expect this mixture to be a homogenous mixture or a heterogenous mixture and explain why. 3

It is a heterogenous mixture. A heterogenous mixture has a non-uniform composition. When three solids are mixed due to their large particle size (relatively), they will not be mixed evenly. Therefore, different samples of the mixture will have different composition.

Feedback: many students mentioning that this is in solution – must read the question – there is no water present. Therefore their reasoning for it being a heterogenous mixture is flawed.

| Marking Criteria | Mark |
|---|------|
| <ul style="list-style-type: none"> Correctly identifies the mixture as a heterogenous mixture Explains that a heterogenous mixture is not uniform in composition Explains that the nature of these substances means that they would be unlikely to mix evenly if all of them are solid (e.g. different densities means they will likely have different layers) | 3 |
| <ul style="list-style-type: none"> Correctly identifies the mixture as heterogenous and explains that it is not uniform in composition but does not adequately explain why | 2 |
| <ul style="list-style-type: none"> Correctly identifies it is heterogenous ONLY OR Incorrectly identifies it but identifies some correct features of a homogenous mixture | 1 |

- (b) Draw a flow diagram that shows how one could effectively separate this mixture to collect pure samples of each of the three substances. 3

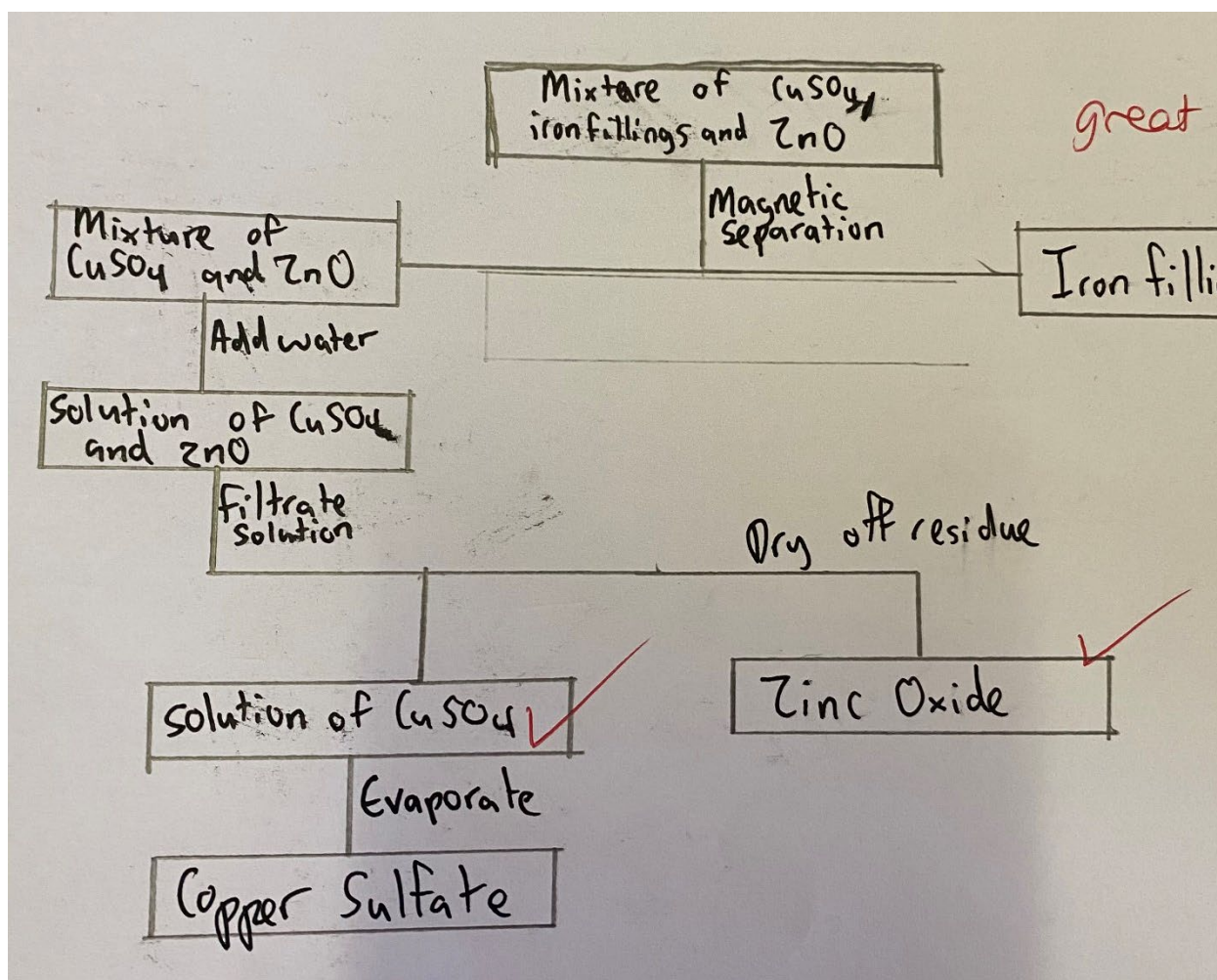

Feedback: samples must be pure (in particular, not wet). Decanting won't completely separate substances, therefore filtration is used. It should also be a practical way to do it in a science lab, therefore heating it to high temperatures to use the difference of melting points is not practical.

| Marking Criteria | Mark |
|---|------|
| <ul style="list-style-type: none"> Flow chart is complete and accurate to show how to acquire pure samples of each substance, including the names of the processes involved Presented in the form of a flow chart | 3 |
| <ul style="list-style-type: none"> Only two pure samples correctly collected OR Three pure samples and not in a flow chart | 2 |
| <ul style="list-style-type: none"> One pure substance only | 1 |